

WELDING OPERATIONS, II

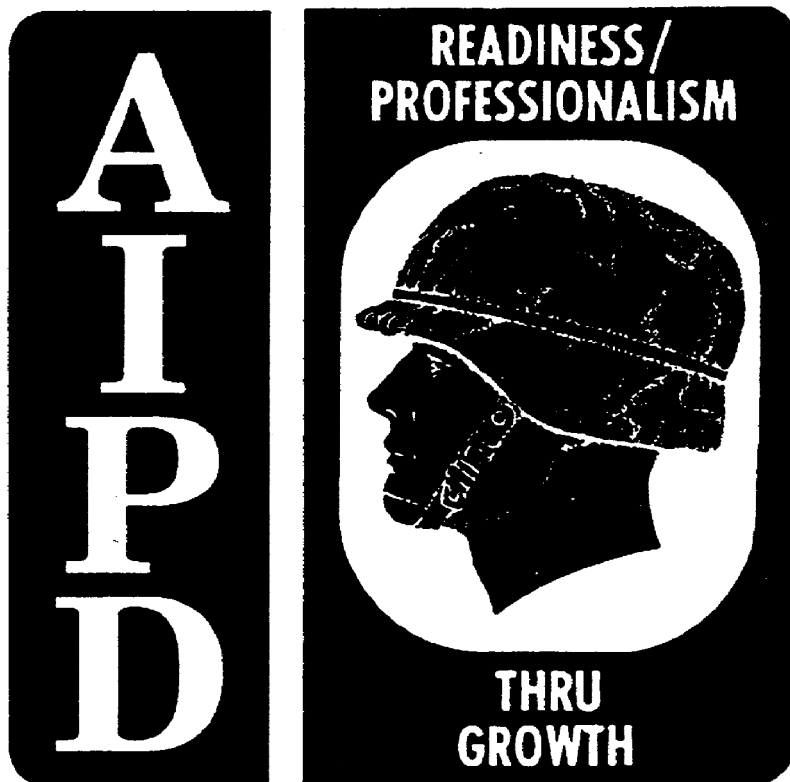

THE ARMY INSTITUTE FOR PROFESSIONAL DEVELOPMENT
ARMY CORRESPONDENCE COURSE PROGRAM

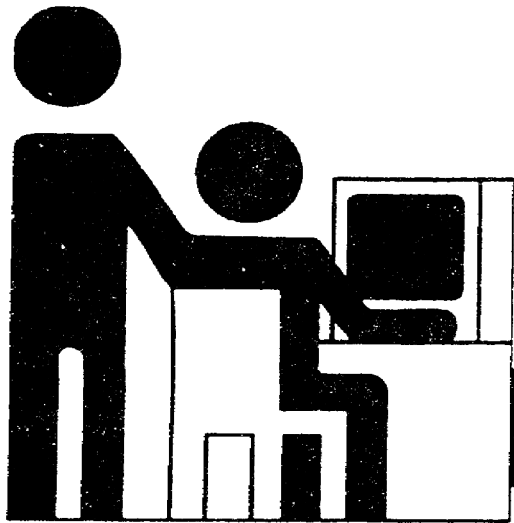

Notice to Students

Use the Ordnance Training Division website,
<http://www.cascom.army.mil/ordnance/>,
to submit your questions, comments, and suggestions
regarding Ordnance and Missile & Munitions
subcourse content.

If you have access to a computer with Internet capability and can receive e-mail, we recommend that you use this means to communicate with our subject matter experts. Even if you're not able to receive e-mail, we encourage you to submit content inquiries electronically. Simply include a commercial or DSN phone number and/or address on the form provided. Also, be sure to check the Frequently Asked Questions file at the site before posting your inquiry.

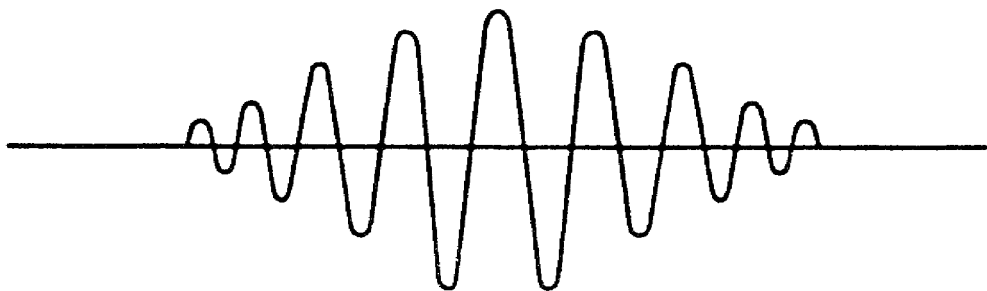

WELDING OPERATIONS, II

**SUBCOURSE OD1654
Edition 8**

**United States Army Combined Arms Support Command
Fort Lee, VA 23801-1809**

6 Credit Hours

GENERAL

The purpose of this subcourse is to introduce the student to the inert gas welding processes, and maintenance of welding equipment.

The scope of this subcourse consists of the inert gas welding principles, equipment, and safety precautions; the gas metal-welding principles operations, and equipment nomenclature; and the procedures for troubleshooting and repairing welding equipment.

Six credit hours are awarded for successful completion of this subcourse.

Lesson 1: INERT GAS WELDING PRINCIPLES, EQUIPMENT, AND SAFETY PRECAUTIONS;
GAS METAL-WELDING PRINCIPLES, OPERATIONS, AND EQUIPMENT
NOMENCLATURE; AND PROCEDURES FOR TROUBLESHOOTING WELDING
EQUIPMENT AND DETERMINING METHODS OF REPAIR

TASK 1: Describe the inert gas and gas metal-arc welding principles, operations, equipment nomenclature, and safety precautions.

TASK 2: Describe the procedures for troubleshooting welding equipment and determining methods of repair.

WELDING OPERATIONS II - OD1654

TABLE OF CONTENTS

Section	Page
TITLE.....	i
TABLE OF CONTENTS.....	ii
Lesson 1: INERT GAS WELDING PRINCIPLES, EQUIPMENT, AND SAFETY PRECAUTIONS; GAS METAL-WELDING PRINCIPLES, OPERATIONS, AND EQUIPMENT NOMENCLATURE; AND THE PROCEDURES FOR TROUBLESHOOTING WELDING EQUIPMENT AND DETERMINING METHODS OF REPAIR.....	1
Task 1: Describe the inert gas and gas metal-arc welding principles, operations, equipment nomenclature, and safety precautions.....	1
Task 2: Describe the procedures for troubleshooting welding equipment and determining methods of repair	33
Practical Exercise 1.....	72
Answers to Practical Exercise 1	74
REFERENCES.....	75

The passing score for ACCP material is 70%.

WELDING OPERATIONS II - OD1654 - LESSON 1/TASK 1

LESSON 1

INERT GAS WELDING PRINCIPLES, EQUIPMENT, AND SAFETY PRECAUTIONS; GAS METAL-WELDING PRINCIPLES, OPERATIONS, AND EQUIPMENT NOMENCLATURE; AND PROCEDURES FOR TROUBLESHOOTING WELDING EQUIPMENT AND DETERMINING METHODS OF REPAIR

TASK 1. Describe the inert gas and gas metal-arc welding principles, operations, equipment nomenclature, and safety precautions.

CONDITIONS

Within a self-study environment and given the subcourse text, without assistance.

STANDARDS

Within three hours

REFERENCES

No supplementary references are needed for this task.

1. Introduction

One of the greatest advances in welding has been the development of a welding method that does not require the application of a flux before or during welding. This is accomplished by using an inert gas to keep air, which would contaminate the weld, away from the arc and the molten metal. This task describes two welding processes that are used for this purpose. They are: tungsten inert gas (TIG) shielded arc, and metal inert gas (MIG) electric arc welding. Even though inert gas shielded arc welding imposes a need for more complex equipment, as compared to oxyacetylene welding, the advantages involved have justified its adoption for use by the U.S. Army in the field. The MIG welding process is the newer of these two recently developed processes. The two processes are used to weld all types of metal, but are especially useful for

welding the hard-to-weld metals such as aluminum, magnesium, and titanium.

This task begins by describing the safety precautions for inert gas shielded arc welding, after which it proceeds to describe the equipment, principles, and operation of inert gas welding.

2. Safety Precautions

a. *Potential Hazards.* Inert gas shielded arc welding processes have certain dangers associated with them. The hazards which are peculiar to or might be increased by gas shielded arc welding are gases, radiant energy, radioactivity from thoriated tungsten electrodes, and metal fumes.

b. *Gases.* Ozone concentration increases with the type electrode used, amperage, extension of arc time, and increased argon flow. If welding is carried out in confined spaces and poorly ventilated areas, the ozone concentration may increase to harmful levels. The exposure level to ozone will be reduced by the protective measures described in subparagraph 2i, beginning on page 4.

c. *Nitrogen Oxides.* In some cases, natural ventilation may be sufficient to reduce the hazard of exposure to nitrogen oxides during welding operations. Nitrogen oxide concentrations will be very high when performing gas tungsten-arc cutting of stainless steel, using a 90 percent nitrogen-10 percent argon mixture. Further, high concentrations of nitrogen oxides have been found during experimental use of nitrogen as shield gas.

d. *Carbon Dioxide and Carbon Monoxide.* Carbon dioxide is chemically dissociated by the heat of the arc to form carbon monoxide gas. The hazard from inhalation of these gases by the welder will be minimal provided ventilation requirements are satisfied. However, where the welding fumes pass through the welder's breathing zone, or where welding is performed in a confined space, ventilation as described in subparagraph 2i, beginning on page 4, must be provided.

e. *Chlorinated Solvents.* The vapors from some chlorinated solvents, such as carbon tetrachloride, trichloroethylene, and perchloroethylene break down under the ultraviolet radiation of an electric arc and form a toxic gas. Welding in areas where these

WELDING OPERATIONS II - OD1654 - LESSON 1/TASK 1

vapors are present should be avoided. In addition, these solvents vaporize easily, and their prolonged inhalation can be hazardous. Eye, nose, and throat irritation can result when the welder is exposed to these substances. Sources of these vapors can be wiping rags, vapor degreasers, or open containers of the solvent. Decomposition of these solvents can occur even at a considerable distance from the arc; therefore, these solvents should be located so that no solvent vapor will reach the welding area.

f. *Radiant Energy.*

(1) *Effects on the Eyes and Face.* The arc welding arc, as well as oxyacetylene gas flames, produce ultraviolet and infrared rays which have a harmful effect on the eyes and skin if continuously or repeatedly exposed. The usual effect of ultraviolet radiation is to sunburn the surface of the eye, which is painful and disabling. Ultraviolet radiation may also produce the same effects on the skin as a severe sunburn. The production and intensity of this radiation doubles, in comparison to shielded metal arc, when gas-shielded arc welding is performed. Therefore, a protective helmet with a filter lens should be used for the welding methods and base metal specified below:

Welding Method	Base Metal	Lens Number
MIG	Ferrous	12*
	Nonferrous	11
TIG	Ferrous	12*
	Nonferrous	11

* Besides the helmet, the operator wears Number 2 flash goggles. Personnel working close by should wear the same goggles. A number 10 shade lens should be used when welding with currents of 75 to 200 amperes.

(2) *Effects on Skin.* Infrared radiations have the effect of heating the tissue with which they come in contact. Therefore, if the heat is not sufficient to cause an ordinary thermal burn, the exposure is minimal. But protective clothing is required for any welding operation. The type of protective clothing required varies depending on the size, nature, and location of the work to be performed. Leather and wool clothing, however, has been found preferable to cotton clothing for wear

WELDING OPERATIONS II - OD1654 - LESSON 1/TASK 1

during gas-shielded arc welding. Cotton clothing is not recommended because it tends to disintegrate within fourteen days, presumably because of the high ultraviolet radiation emitted during arc-welding and cutting.

g. *Radioactivity from Thoriated Tungsten Electrodes.* Gas tungsten-arc welding using these electrodes may be employed with no significant hazard to the welder or other occupants in the immediate area. Generally, no special ventilation or personal protective equipment other than that specified in subparagraph 2h below is required for protection when welding with thoriated tungsten electrodes.

h. *Metal Fumes.* The physiological response from exposure to metal fumes will vary depending upon the metal being welded. Therefore, proper ventilation and respiratory equipment, as described in subparagraph 2i below, must be employed to prevent hazardous exposure to these fumes.

i. *Protective Measures.* To protect the welder and other personnel in the vicinity of the welding area from the effects of the hazards discussed in subparagraphs 2b through 2h above, the following protective measures are recommended.

(1) *Screened Areas.* Shielding screens must be used to protect personnel passing by or working in the general area. These screens should be mounted about two feet above the floor to permit the air to circulate from underneath, carrying the gases, fumes, and oxides up and dissipating them into the atmosphere. The use of a portable fan is recommended, if welding is performed at so low a level that the screen must be extended nearer to the floor to protect other worker personnel from the welding arc glare.

(2) *Ventilation in Confined Spaces.* To prevent contamination of the general work area, exhaust fans will be installed as part of the building to keep the amount of toxic fumes, gas or dust below the acceptance concentrations of toxic dust and gases. The standards for these accepted concentrations are specified in: the American National Standard Institute Standard 7.37; the latest Threshold Limit Values (TLV) of the American Conference of Governmental Industrial Hygienists; and in the exposure limits established by Public

WELDING OPERATIONS II - OD1654 - LESSON 1/TASK 1

Law 91-596, Occupational Safety and Health Act of 1970. The requirements for adequate ventilation are stated in the American National Standards Institute Standard Z49.1-1973, Safety in Welding and Cutting, published by the American Welding Society.

(3) *Respiratory Protective Equipment.* Welding may produce fumes and gases (brazing produces cadmium and fluoride fumes) that are hazardous to health. Therefore, individual respiratory protective equipment should be used and well maintained to avoid breathing these fumes and gases. Further, respiratory protective equipment should not be transferred from one individual to another without being disinfected. Only respiratory protective equipment approved by the US Bureau of Mines, National Institute of Occupational Safety and Health, or other governmental approved testing agency should be used. The procedures for selection, care, and maintenance of respiratory protective equipment are contained in Practices for Respiratory Protection, American National Standard Institute Standard 788.2, and TB MED 223.

j. The following paragraph describes the various types of gas shielding used in inert gas welding to keep air away from the arc and the molten metal during welding operations.

3. Shielding Gases for Inert-Gas Welding

a. *General.* The most common method of preventing contact of the surrounding air with the molten metal during welding operations is to use a gas shielding. In the oxyacetylene and oxyhydrogen processes, gas shielding results naturally from the mixture of combustion products, which include hydrogen, water vapor, carbon monoxide, and carbon dioxide. In the covered-electrode metal arc process, gas shielding is obtained when the electrode covering material decomposes. In the inert-gas welding processes, argon and helium have long been considered ideal for most metal welding operations.

b. *Argon.* Argon provides the most stable and easy to control arc. Argon is inert and about 1 1/3 times heavier than air, and 10 times heavier than helium. Argon is produced from the world's most abundant raw material, the very air we breathe. The process consists essentially of repeated

WELDING OPERATIONS II - OD1654 - LESSON 1/TASK 1

expansion and contraction of air until it becomes so cold (300° F below zero) that it liquifies. Argon is recovered by raising the temperature of the liquified oxygen. Because it is heavier, it pushes aside the lighter air molecules and prevents oxidation of the electrode, the molten puddle, and the heat affected zone adjacent to the puddle.

c. *Helium.* Helium is lighter and tends to rise from the weld. Its superior electrical characteristics, however, mean more heat can be obtained at the equivalent current and arc length. Helium, therefore, is more suitable for high speed welding, or for cutting or welding thicker materials. Its major disadvantage is that two to three times as much helium as argon is required to do the same job.

d. *Argon-Helium Mixtures.* Quite often, optimum welding conditions may be obtained by combining shielding gases in various proportions. In using such mixtures, it is possible to achieve high welding speeds and avoid such undesirable conditions as excessive spatter, shallow penetrations, poor cleaning, and high gas consumption.

e. *Carbon Dioxide.* Carbon dioxide is being used increasingly as a shielding gas because it is considerable cheaper than argon or helium. Mixtures such as 75 percent argon and 25 percent carbon dioxide are employed to make use of the best properties of both gases. Increasing the percentage of carbon dioxide in the mixture allows higher welding speeds and yields deeper penetration. Such mixtures are especially suited to welding mild steel.

4. Tungsten Inert Gas (TIG) Shielded Arc Welding

a. *Characteristics.*

(1) This is a welding process in which coalescence is produced by heating with an electric arc between a metal electrode and the work. Shielding of the arc and the molten metal is obtained through the use of an inert gas. A tungsten electrode is used because of its high melting point, and in the presence of the inert gas the electrode is practically nonconsuming. Filler metal, if used, is added to the weld in the same manner as in oxyacetylene welding.

WELDING OPERATIONS II - OD1654 - LESSON 1/TASK 1

(2) In addition to its shielding action, the inert gas also performs a cleaning action that is beneficial when welding aluminum, magnesium, beryllium, copper, and some alloys containing additions of aluminum or beryllium which form refractory oxides.

(3) With the tungsten inert welding process, welds can be made in all positions, and in practically all metals, without the use of flux. No significant amount of oxide is formed; therefore, fluxes are not required.

(4) Either direct current (dc) or alternating current (ac) electricity can be used to perform inert gas arc welding operations, depending on the type metal to be welded. When welding aluminum with this welding process, the use of alternating current is preferred. The use of alternating current produces an oxide cleaning action, resulting in a better weld in aluminum. Direct current, reverse polarity (dcrp), is used for welding these metals in very thin sections.

b. *Advantages.* The TIG shielded arc welding process has certain advantages over other welding processes as described in the following subparagraphs.

(1) It provides freedom from the need for using a flux, either on the work or on the filler rod, thus eliminating the flux removal problem.

(2) It permits visual control while welding in any position.

(3) It produces minimum distortion in the base metal.

c. *Type of Inert Gas Used.*

(1) Argon is the type of inert gas most commonly used because it affords better control of the molten metal pool and of the arc. The argon gas also forms an envelope which protects the molten metal from contact with the air. The results are that the weld metal remains brighter, is less cloudy, and produces a better quality weld which is free of contamination.

WELDING OPERATIONS II - OD1654 - LESSON 1/TASK 1

(2) Helium gas is used in cases where more intense heat or deep penetration into the base metal is required. Therefore, helium is used only when performing high speed welding, or when welding or cutting thicker metal.

d. *Tungsten Electrodes.*

(1) Tungsten can withstand higher temperatures than the normal electrode used in arc welding. But it can also be consumed if the temperature of the arc is too hot. Therefore, there is a limit to the current carrying capacity of tungsten electrodes. This limit, together with the heating characteristics of the work in terms of polarity, has led to the use of alternating current for almost all tungsten arc welding.

(2) The size of the electrode is determined by the current which, in turn, is a function of the material thickness. Nonconsuming electrodes for TIG welding are of four types: pure tungsten, tungsten containing 1 or 2 percent thorium, and tungsten containing 0.3 to 0.5 percent zirconium. Each type of tungsten electrode can be identified by painted end marks, as follows:

- (a) Green - pure tungsten.
- (b) Yellow - 1 percent thorium.
- (c) Red - 2 percent thorium.
- (d) Brown - 0.3 to 0.5 percent zirconium.

(3) Pure tungsten (99.5 percent tungsten) electrodes are generally used on less critical welding operations rather than the tungstens which are alloyed. This type of electrode has a relatively low current carrying capacity and a low resistance to contamination.

(4) Thoriated tungsten electrodes (1 or 2 percent thorium) are superior to pure tungsten electrodes because of their higher electron output, better arc-starting and arc stability, high current-carrying capacity, longer life, and greater resistance to contamination.

WELDING OPERATIONS II - OD1654 - LESSON 1/TASK 1

(5) Tungsten electrodes containing 0.3 to 0.5 percent zirconium generally fall between pure tungsten electrodes and thoriated tungsten electrodes in terms of performance. There is, however, some indication of better performance in certain types of welding using ac electric power.

(6) Better control of the arc can be obtained if the tungsten electrode is dressed to a point as shown in figure 1, view A, on the following page. When electrodes are not grounded, they must be operated at maximum current density to obtain reasonable arc stability. Tungsten electrode points are difficult to maintain if standard direct current equipment is used as a power source and touch starting of the arc is standard practice. Maintenance of electrode shape and the reduction of tungsten inclusions in the weld can best be effected by superimposing a high-frequency current on the regular welding current. Tungsten electrodes alloyed with thorium and zirconium retain their shape longer when touch-starting is used.

(7) The electrode extension beyond the gas cup should be kept as short as possible with the type of joint being welded. For example, an extension beyond the gas cup of 1/8 inch might be used for butt joints in light gage material, while an extension of approximately 1/4 inch to 1/2 inch might be necessary on some fillet welds. The tungsten electrode or torch should be inclined slightly and the filler metal added carefully, avoiding contact with the tungsten to prevent contamination of the electrode. If contamination does occur, the electrode must be removed, reground, and replaced in the torch.

e. *Welding Current.*

(1) *General.* Standard alternating current welding transformers, with 100 volts or less open circuit potential, are used in this method of welding. These transformers usually require a superimposed high frequency voltage for starting and maintaining the arc. The polarity to be used with a specific type of electrode is established by the manufacturer.

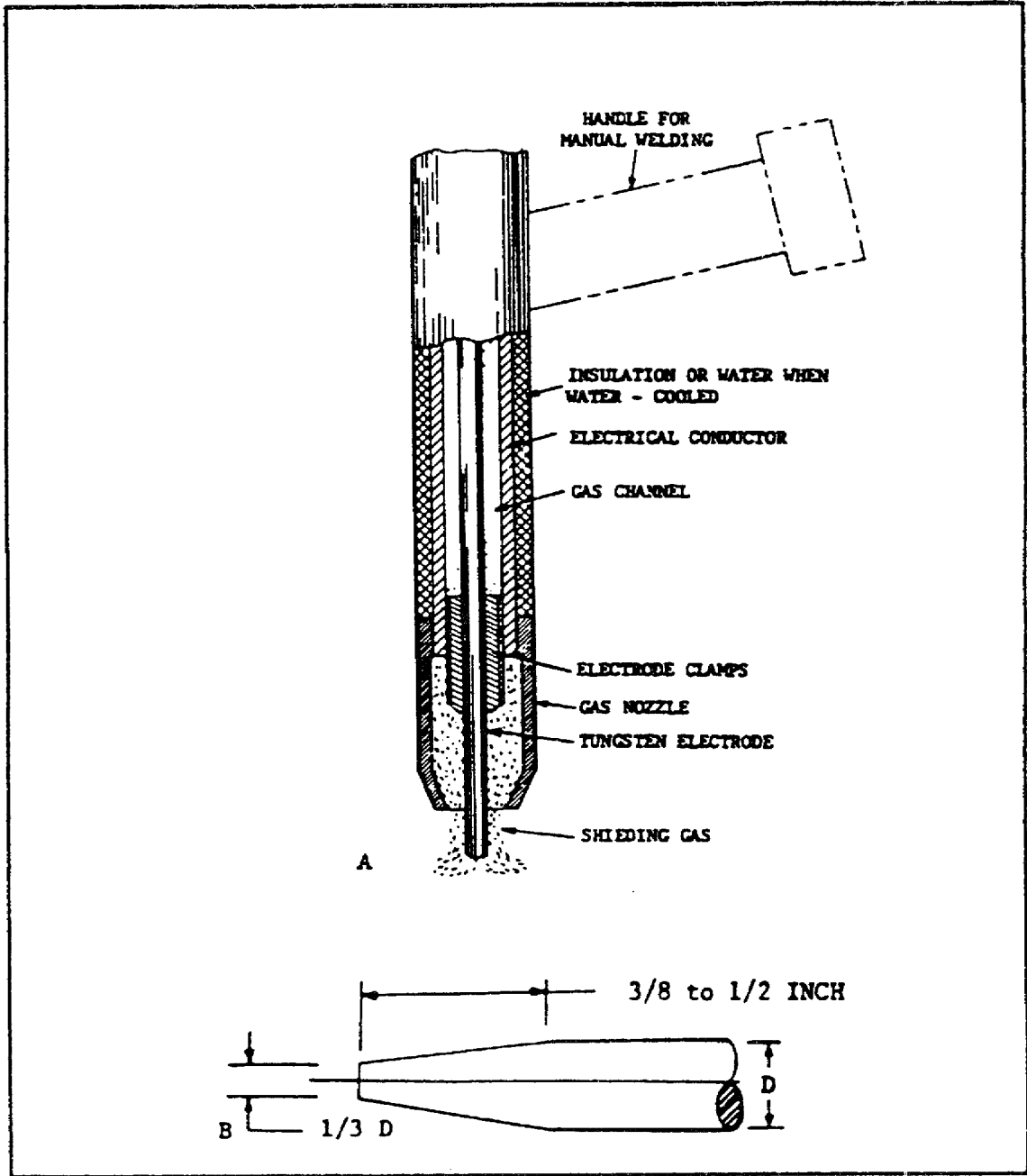

FIGURE 1. INERT GAS METAL ARC WELDING ELECTRODE HOLDER.

(2) *Direct Current Welding.*

(a) In direct current welding, the welding current circuit may be hooked up as either straight polarity (dcsp) or reverse polarity (dcrp). For dcsp, the machine connections are electrode negative and workpiece positive as shown in figure 2, view A (1), on the following page. The electron

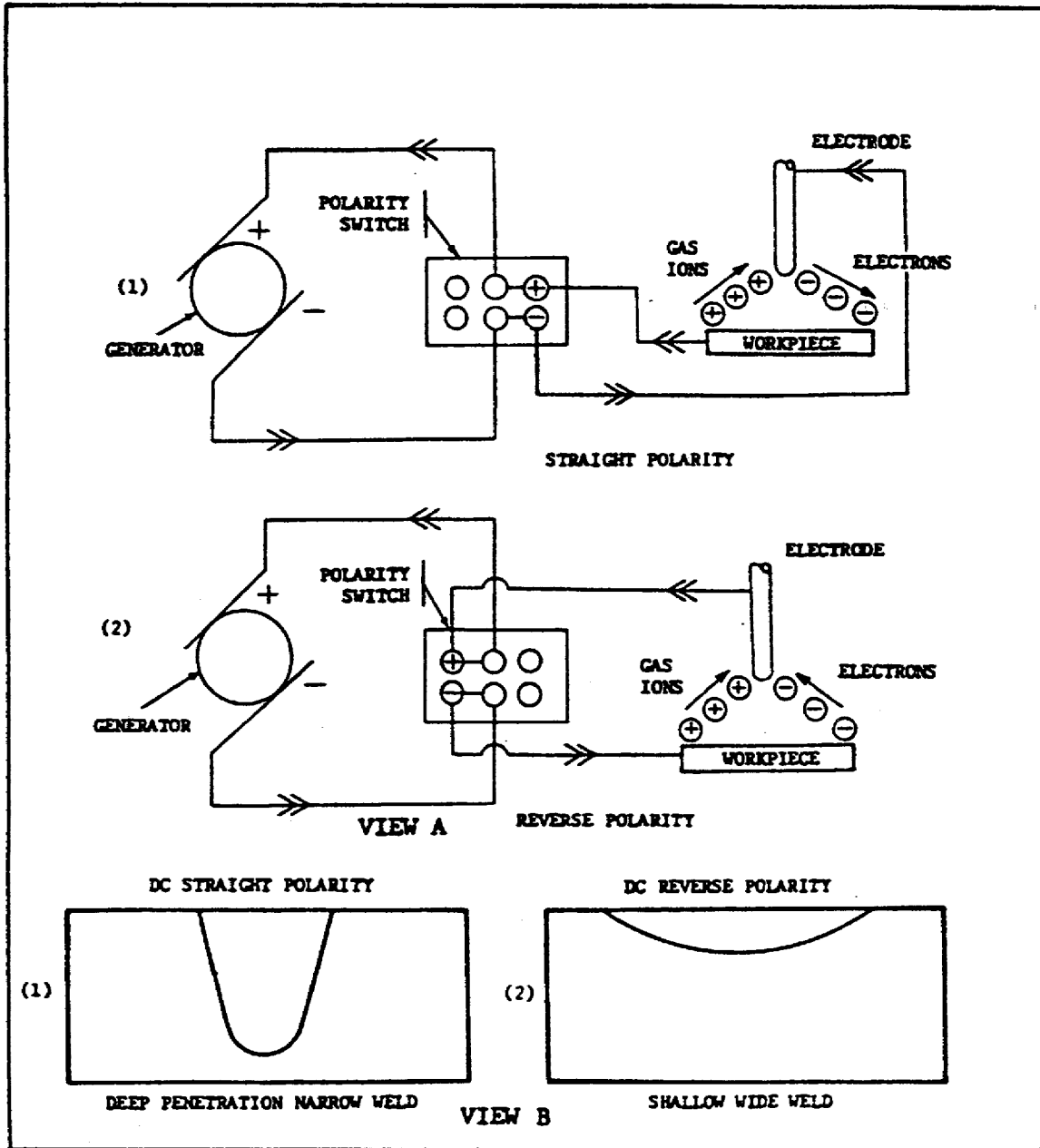

FIGURE 2. WELDING CURRENT POLARITY AND EFFECTS.

flow in the circuit formed by this connection is from the electrode to the workpiece (base metal plate). For dcrp, the welding machine connections are electrode positive, and workpiece negative, as shown in figure 2, view A (2). The electron flow in this circuit is from the workpiece to the electrode.

(b) In straight polarity welding, the electrons hitting the plate at a high velocity exert a

WELDING OPERATIONS II - OD1654 - LESSON 1/TASK 1

considerable heating effect on the plate. In reverse polarity welding, the opposite occurs; the electrode acquires the extra heat, which tends to melt off the end of the electrode. Thus, for any given amount of welding current, dcrp requires a larger diameter electrode than dcsp. For example, a 1/16 inch diameter pure tungsten electrode can handle 125 amperes of welding current under straight polarity conditions. But if this amount of current is reversed, it would melt off the electrode and contaminate the weld metal. A 1/4 inch diameter pure tungsten electrode, however, can handle this amount of current satisfactorily and safely. When heavy coated electrodes are used, the composition of the coating and the gases it produces may alter the heat conditions, producing greater heat on the negative side of the arc. One type of coating may provide the most desirable heat balance with straight polarity, while another type of coating on the same electrode may provide a more desirable heat balance with reverse polarity.

(c) These opposite heating effects influence not only the welding action but also the shape of the weld obtained. For example, dcsp welding will produce a narrow, deep weld as shown in figure 2, view B (1), on the previous page. Because of the larger electrode diameter and lower currents generally used, dcrp welding gives a wide and relatively shallow weld, as shown in figure 2, view B (2).

(d) One other effect of dcrp welding should be considered here; namely, the so-called cleaning effect that seems to occur. Although the exact reason for this surface cleaning action is not known, it seems probable that either the electrons leaving the plate or the gas ions striking the plate tend to break up the surface oxides, scales, and dirt usually present.

(e) In general, straight polarity is used with all mild steel, bare, or thinly coated electrodes. Reverse polarity is used in the welding of such non-ferrous metals as aluminum, bronze, monel, and nickel. Reverse polarity is also used with some types of electrodes for making vertical and overhead welds. The proper polarity for a given electrode can be recognized by the sharp, cracking sound of the arc. The wrong polarity will cause the arc to emit a hissing sound, and the welding bead will be difficult to control.

(3) *Alternating Current.*

(a) Alternating current welding, theoretically, is a combination of dcsp and dcrp welding. This can be best explained by showing the three current waves. As shown in figure 3, view A, on the following page, half of each complete alternating current cycle is dcsp, and the other half is dcrp.

(b) Moisture, oxides, scale, etc., on the surface of the plate tend to prevent, partially or completely, the flow of current in the reverse polarity direction. This is called rectification. For example, if no current at all flowed in the reverse polarity direction, the current wave would look something like that shown in figure 3, view B.

(c) To prevent this rectification from occurring, it is common practice to introduce an additional high-voltage, high-frequency, low-power current into the welding current. This high frequency current jumps the gap between the electrode and the workpiece and pierces the oxide film, thereby forming a path for the welding current to follow. Superimposing this high-voltage, high-frequency current on the welding current gives the following advantages:

1 The arc may be started without touching the electrode to the workpiece.

2 Better arc stability is obtained.

3 A longer arc is possible. This is particularly useful in surfacing and hard-facing operations.

4 Welding electrodes have longer life.

5 The use of wider current range for a specific diameter electrode is possible.

f. *Weld Contour.* A typical weld contour produced with high-frequency stabilized alternating current is shown in figure 3, view C (1). Both the dcsp and dcrp welds are shown in figure 3, view C (2) and (3) for comparison of the penetration contours between the ac and dc welds.

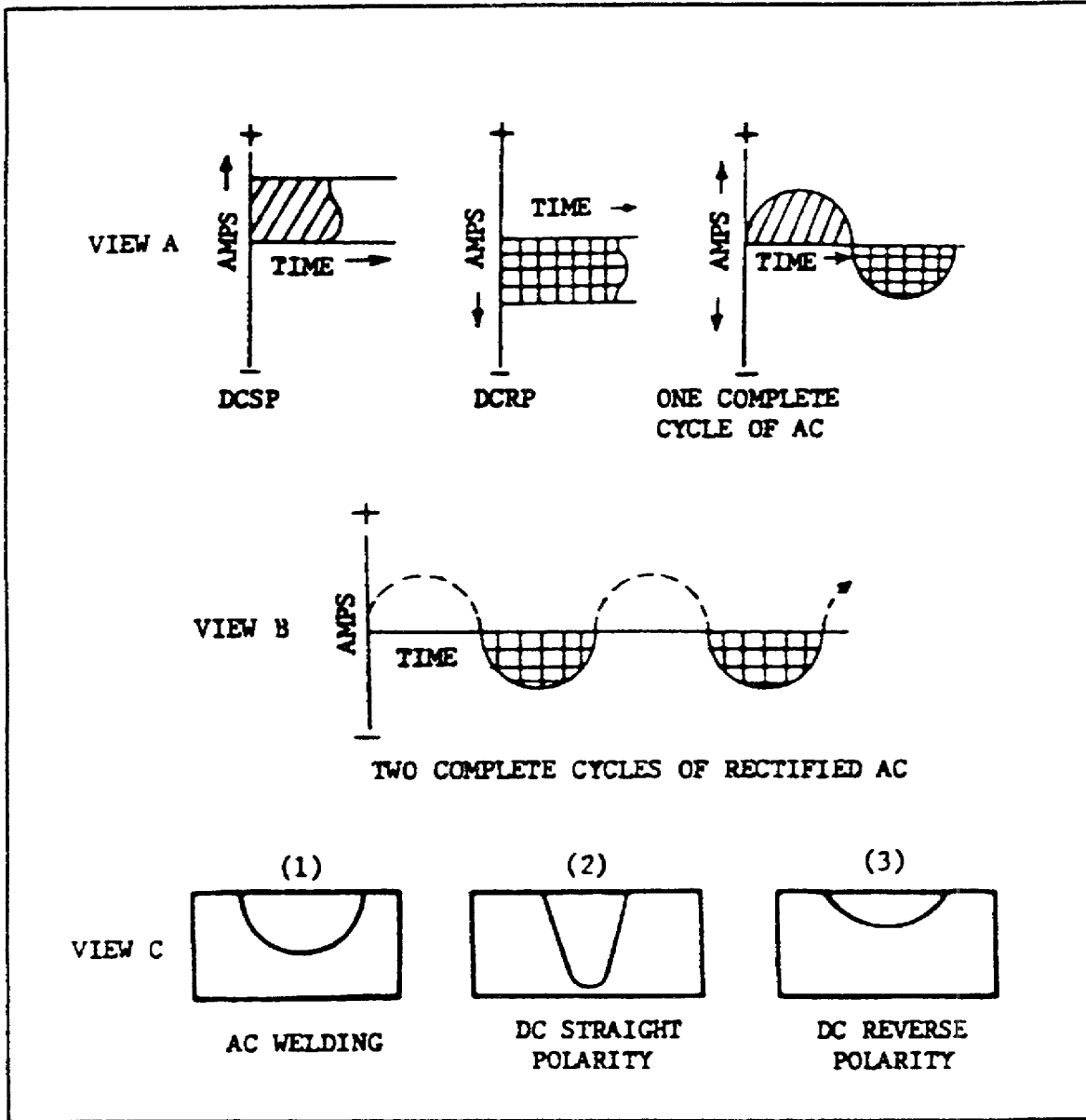

FIGURE 3. AC WAVE, RECTIFIED AC WAVE, AND COMPARISON OF WELD PENETRATION.

g. *Filler Rod.* Sometimes enough parent metal is provided by the design of the joint to form the weld bead. However, filler metal is usually added in bare rod form for hand feeding or in the form of a coil of wire for automatic feeding of the filler rod during welding.

h. *Joint Design.*

(1) *General.* The type of welding joints used in TIG welding operations are the five basic types of joints (butt, lap, corner, edge, and tee) that are used in any of the other welding processes. Almost

WELDING OPERATIONS II - OD1654 - LESSON 1/TASK 1

any TIG weld will be one or a combination of two or more of these five basic types. Selection of the proper design for a particular application will depend primarily on the following factors: physical properties desired in the weld; type of metal being welded; and size, shape, and appearance of the assembly to be welded. Filler metal in the form of a welding rod need not be used if proper reinforcement and complete fusion of the edges can be obtained without it. The joints described in this lesson are but a few of the many that can be successfully TIG welded. They do, however, represent those most frequently used. Many variations of these types can be used to fulfill special job requirements.

(2) *Cleaning.* Proper cleaning of the workpiece prior to welding is essential if welds of good appearance and physical properties are to be obtained. On small assemblies, manual cleaning with a wire brush, steel wool, or a chemical solvent is usually sufficient. For large assemblies or for cleaning on a production basis, vapor degreasing or tank cleaning may be more economical. In any case, be sure to completely remove all oxide, scale, oil, grease, dirt, rust, and other foreign matter from the work surface.

(3) *Square Butt Joint* (figure 4, view A, on the following page). The square butt joint is the easiest to prepare and can be welded with or without filler metal depending on the thickness of the base metal being welded. Joint fitup for this type joint should always be true enough to assure 100 percent penetration with good fusion. When welding light gage material without adding filler metal, extreme care should be taken to avoid low spots and burn through. The heavier thickness will generally require filler metal to provide adequate reinforcement.

(a) *Single-Vee Butt Joint.* The single-vee butt joint is used where complete penetration is required on a material thickness ranging between 1/4 and 3/8 inch. Filler rod must be used to fill in the "vee". The included angle of the "vee" should be approximately 60 degrees; the nose will measure from 1/8 to 1/4 inch, depending on the composition and thickness of the base metal being welded.

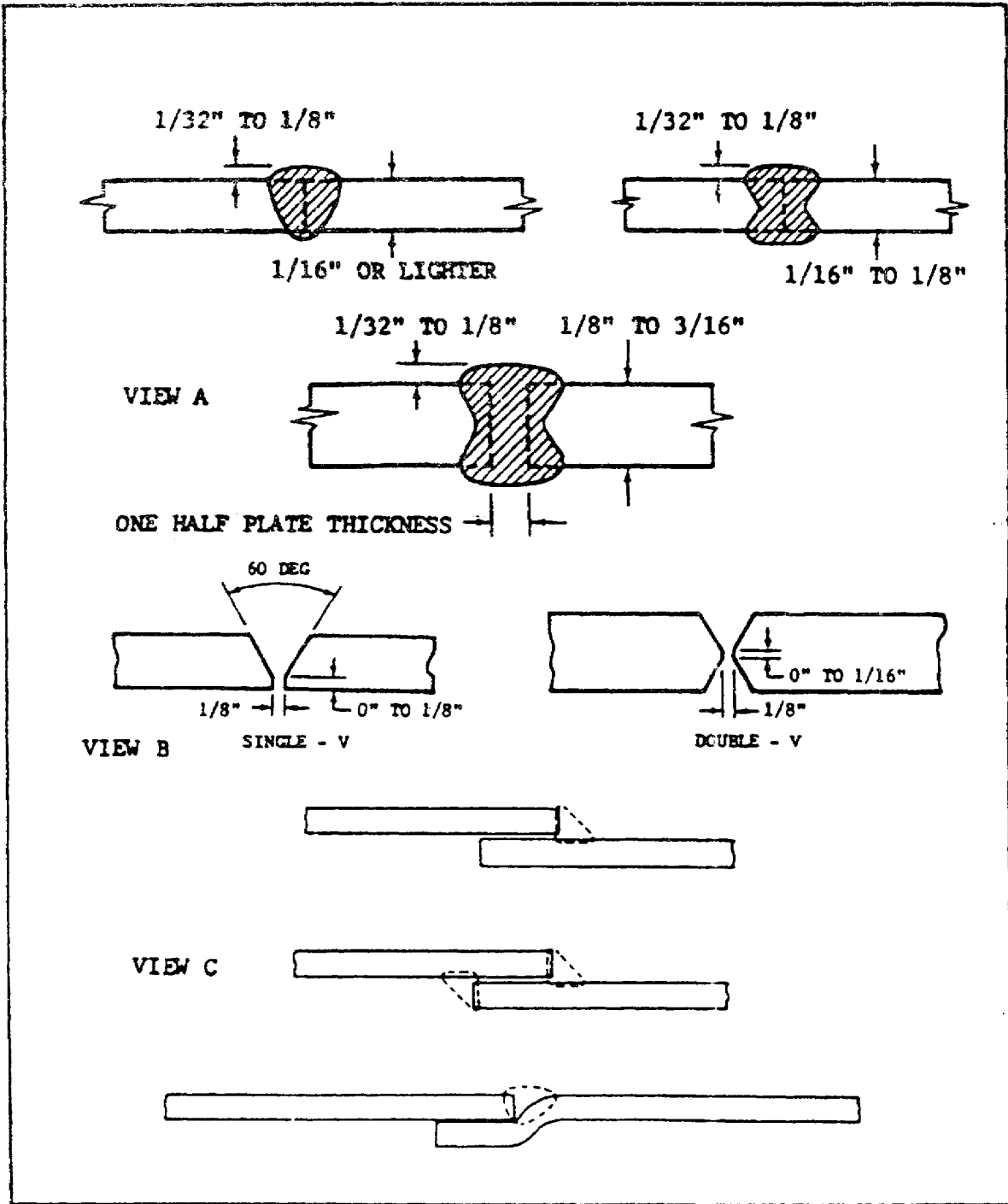

FIGURE 4. BUTT JOINT.

(b) *Double-Vee Butt Joint.* The double-vee butt joint is generally used on stock one-half inch and up, where the design of the assembly being welded permits access to the back of the joint for a second pass. With this type of joint, proper welding techniques will assure a good, sound weld with 100 percent fusion.

WELDING OPERATIONS II - OD1654 - LESSON 1/TASK 1

(4) *Lap Joint* (figure 4, view C, on the previous page). The lap joint has the advantage of eliminating the need for edge preparation. The only requirement for making a good lap weld is that the plates be in close contact along the entire length of the joint to be welded. On material one-fourth inch or less in thickness, lap joints can be made with or without filler rod. When no filler rod is used, care must be taken to avoid low spots or burn through. The lap type of joint is not usually recommended on material thicker than one-fourth inch except for rough fitup. When so used, filler rod must always be added to assure good fusion and build-up. The number of passes required will depend on the thickness of the pieces of base metal being joined.

(5) *Corner Joint* (figure 5, view A, on the following page). Corner joints are frequently used in the fabrication of pans, boxes, and all types of containers as well as for other heavier purposes. The number of passes required will depend on the size of the "vee" or thickness of the base metal. On all corner joints, be sure the pieces are in good contact along the entire edge.

(6) *Edge Joint* (figure 5, view B). Edge joints are used solely for joining light gage metals and can be welded without the use of a filler rod. Since no filler rod metal is required, preparation is simple and the joint is economical to weld.

(7) *Tee Joint*. All tee joints require the addition of a filler rod to provide the necessary build-up of metal between the work pieces of base metals being welded. The number of passes on each side of the joint will depend upon the thickness of the base metal (the material being welded) and the size of the weld desired. When 100 percent penetration is required, be sure that welding current values are adequate for the thickness of the base metal.

i. *Equipment* (figure 6 on page 20).

(1) The basic equipment requirements for manual TIG welding are shown in view A of figure 6 and consist of the welding torch, an electrical power supply, shielding gas, and a water supply. Safety equipment should be used for protection against the arc rays during welding operations.

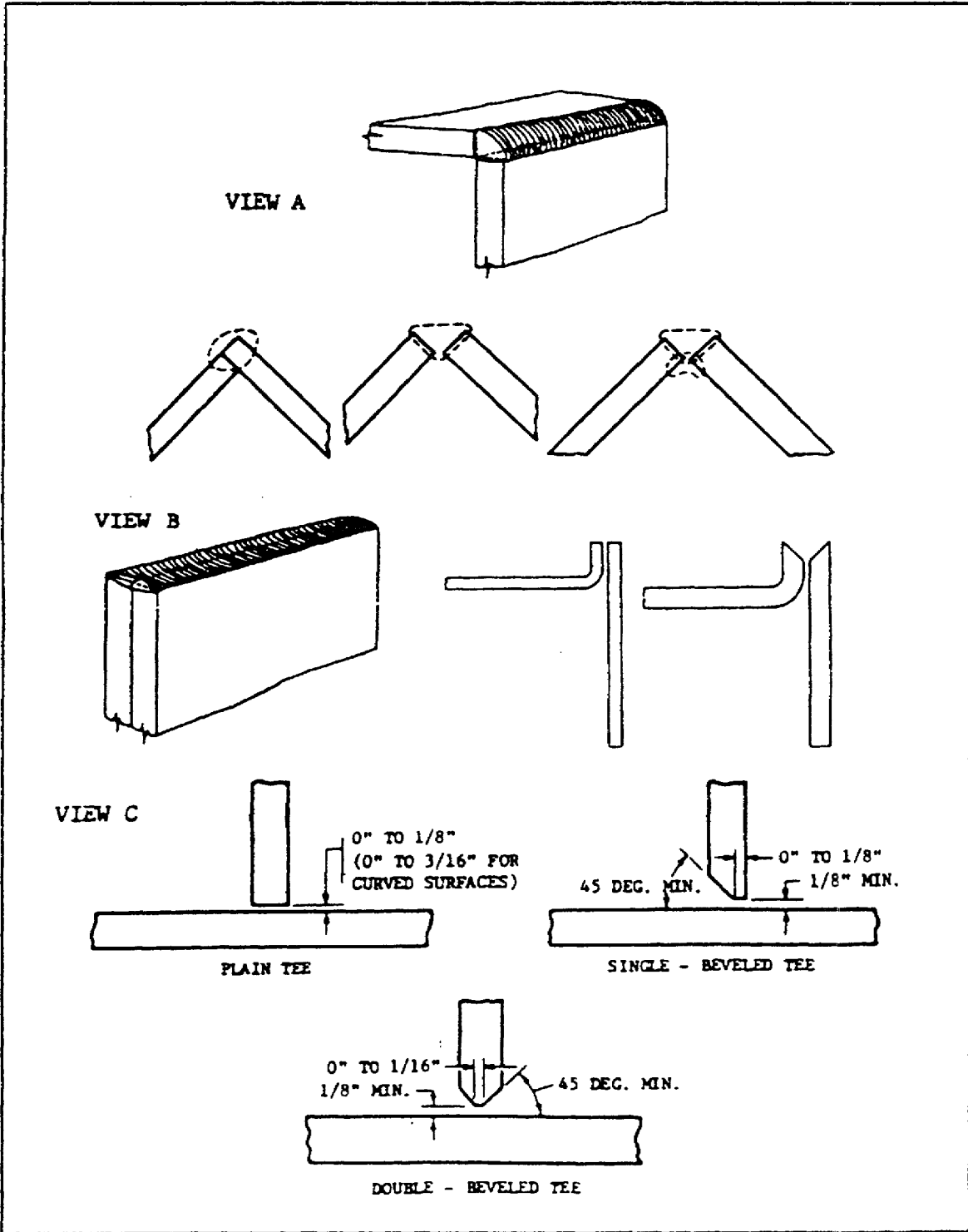

FIGURE 5. CORNER, EDGE, AND TEE JOINTS.

(2) Argon gas is supplied in steel cylinders containing approximately 330 cubic feet at a pressure of 2,000 psi (pounds per square inch). A single or two stage regulator may be used to

control the gas flow. A specially designed regulator containing a flowmeter, as shown in view B of figure 6 on the following page, may be used. The advantage of the flowmeter is that it provides better gas flow control. The flow meter is calibrated in cubic feet per hour (cfh). The correct flow of argon to the torch is set by turning the adjusting screw on the regulator. The rate of flow depends on the kind and thickness of the metal to be welded.

(3) Blanketing of the weld area is provided by a steady flow of argon gas directed through the welding torch (figure 7 on page 21). Since argon is somewhat heavier than air, it pushes the lighter air molecules aside as described in paragraph 3a, on page 5, thereby effectively preventing oxidation of the welding electrode, the molten weld puddle, and the heat-affected zone adjacent to the weld bead.

(4) The tremendous heat of the arc and the high current often used usually necessitate water cooling of the torch. As shown in figure 7, water is circulated through passages in the torch to cool, the torch and the electrode power cable at the handle end of the torch. The cooling water, however, must be clean to prevent blocking of passages which may result in overheating and damage to the torch. Straining or filtering of the water at its source is recommended to cleanse it of foreign matter which might clog up the welding torch.

(5) Since Intermediate Direct Support (IDS) and Intermediate General Support (IGS) field units are not always in the proximity of a public water source, portable self-contained water cooling systems are available for field use. These portable systems consist of a water storage tank and recirculation pump. If such a system is used, it is recommended that antifreeze be mixed in the water during the winter months to prevent it from freezing. Further, the water pressure in some TIG welding systems must be regulated to less than 55 psi. Therefore a water pressure regulator is required. The type water pressure regulator to be used with each TIG welding system is specified in the pertinent equipment operator's manual.

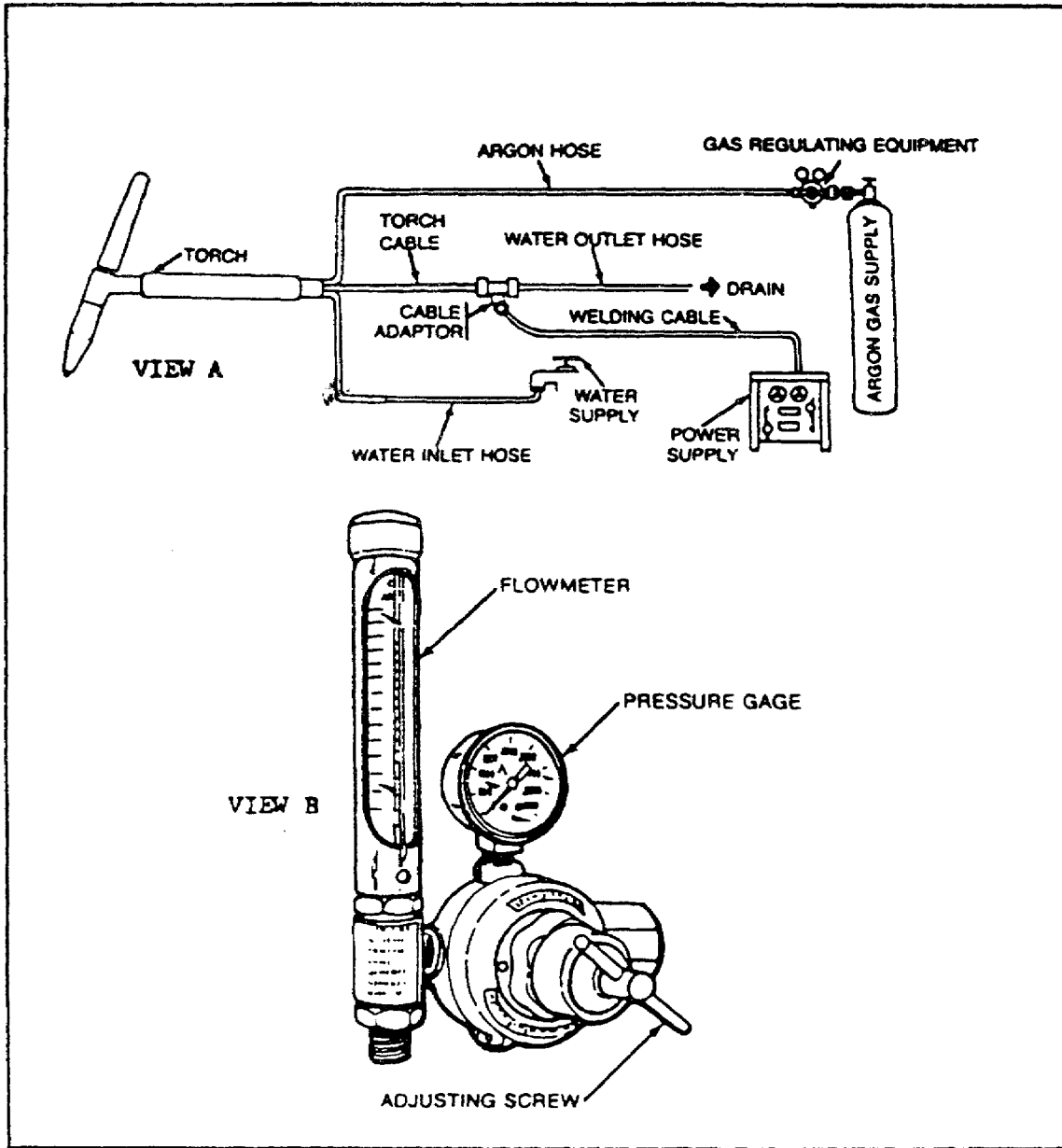

FIGURE 6. GAS TUNGSTEN-ARC (TIG) WELDING EQUIPMENT.

j. Torch Nomenclature.

(1) *Cap*. The cap is made of plastic. It shields the tungsten electrode and prevents the escape of gas from the top of the torch. It also holds and locks the electrode in place.

(2) *Collet*. The collet is made of copper. The electrode fits inside the collet. And when the cap is tightened, the collet squeezes against the electrode, locking the electrode in place.

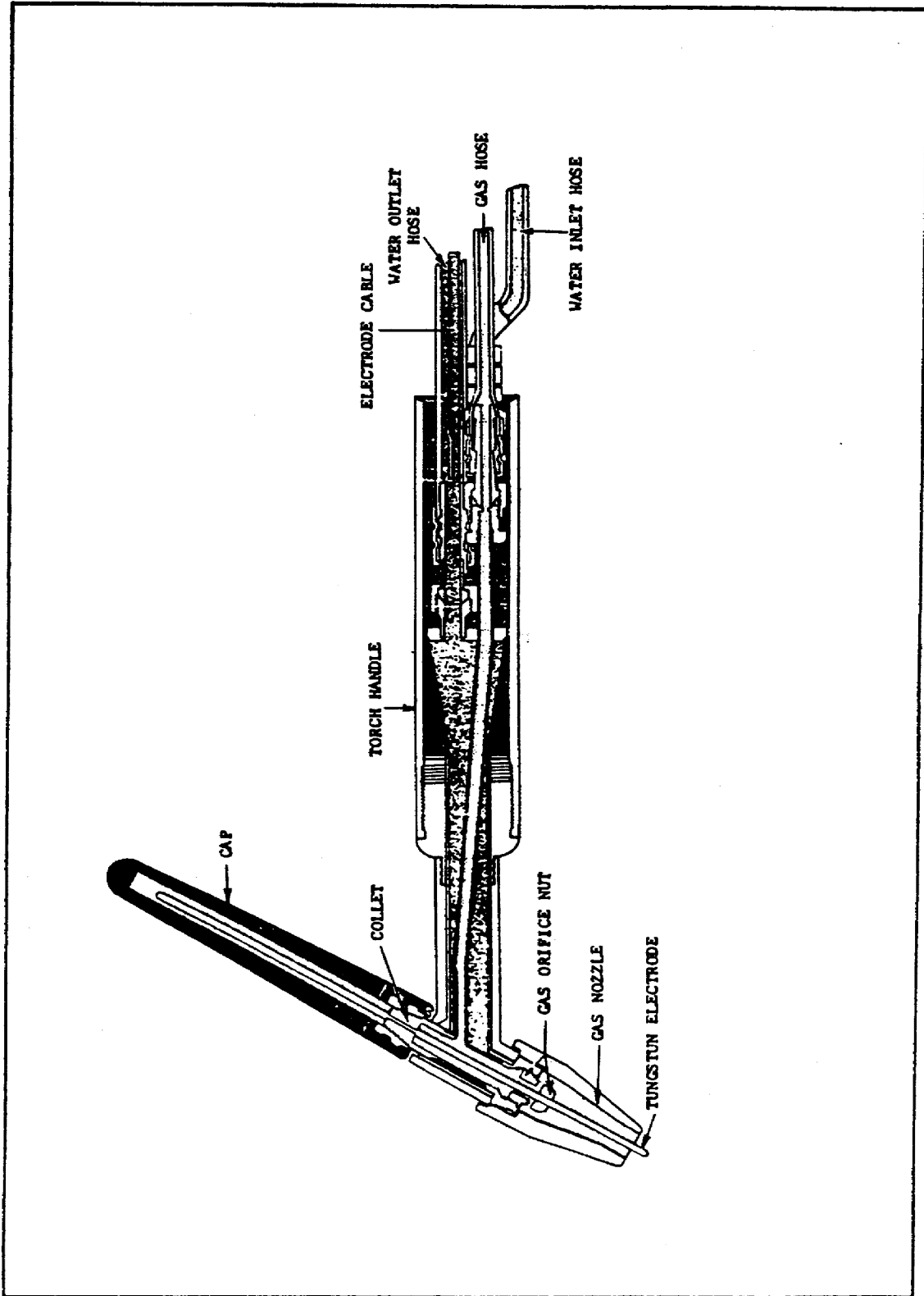

FIGURE 7. TIG WELDING TORCH.

WELDING OPERATIONS II - OD1654 - LESSON 1/TASK 1

(3) *Gas Orifice Nut.* The gas orifice nut allows the gas to escape out of the torch when the gas flow valve (not shown in figure 7 on the previous page) is opened.

(4) *Gas Nozzle.* The gas nozzle directs the flow of shielding gas onto the weld puddle. Two types of nozzles are used; the one for light-duty welding is made of a ceramic material, the one for heavy-duty welding is a water-cooled copper nozzle.

(5) *Torch Handle.* The torch handle is made of plastic to reduce the chance of grounding the torch.

(6) *Hoses.* Three plastic hoses, connected inside the torch handle, carry water and gas, and accommodate the electric power cable. The electric power cable is located inside the water drain line; this allows the cable to stay cool while carrying high amperage current.

k. *Starting the Arc* (figure 8 on the next page).

(1) *Alternating Current.* When using alternating current, the electrode does not have to touch the workpiece to start the arc. The superimposed high frequency current jumps the gap between the welding electrode and the work, thus establishing a path for the welding current to follow. To strike an arc, first turn on the power supply and hold the torch in a horizontal position about 2 inches above the workpiece or starting block as shown in figure 8, view A. Then quickly swing the end of the torch down toward the workpiece, so that the end of the electrode is about one-eighth of an inch above the plate as shown in figure 8, view B. The arc will then strike. (On some alternating current welding machines the electrode must momentarily touch the plate, then be withdrawn to one-eighth of an inch before the arc will start.) This downward motion should be made rapidly to provide the maximum amount of gas protection to the weld zone. When welding aluminum, an initial arc is struck on a starting block to heat the electrode. The arc is then broken and reignited in the weld joint.

(2) *Direct Current.* When using direct current, the same motion is used for striking the arc as in alternating current. In this case, however, the electrode must touch the workpiece in order for the arc to start. As soon as the arc is struck,

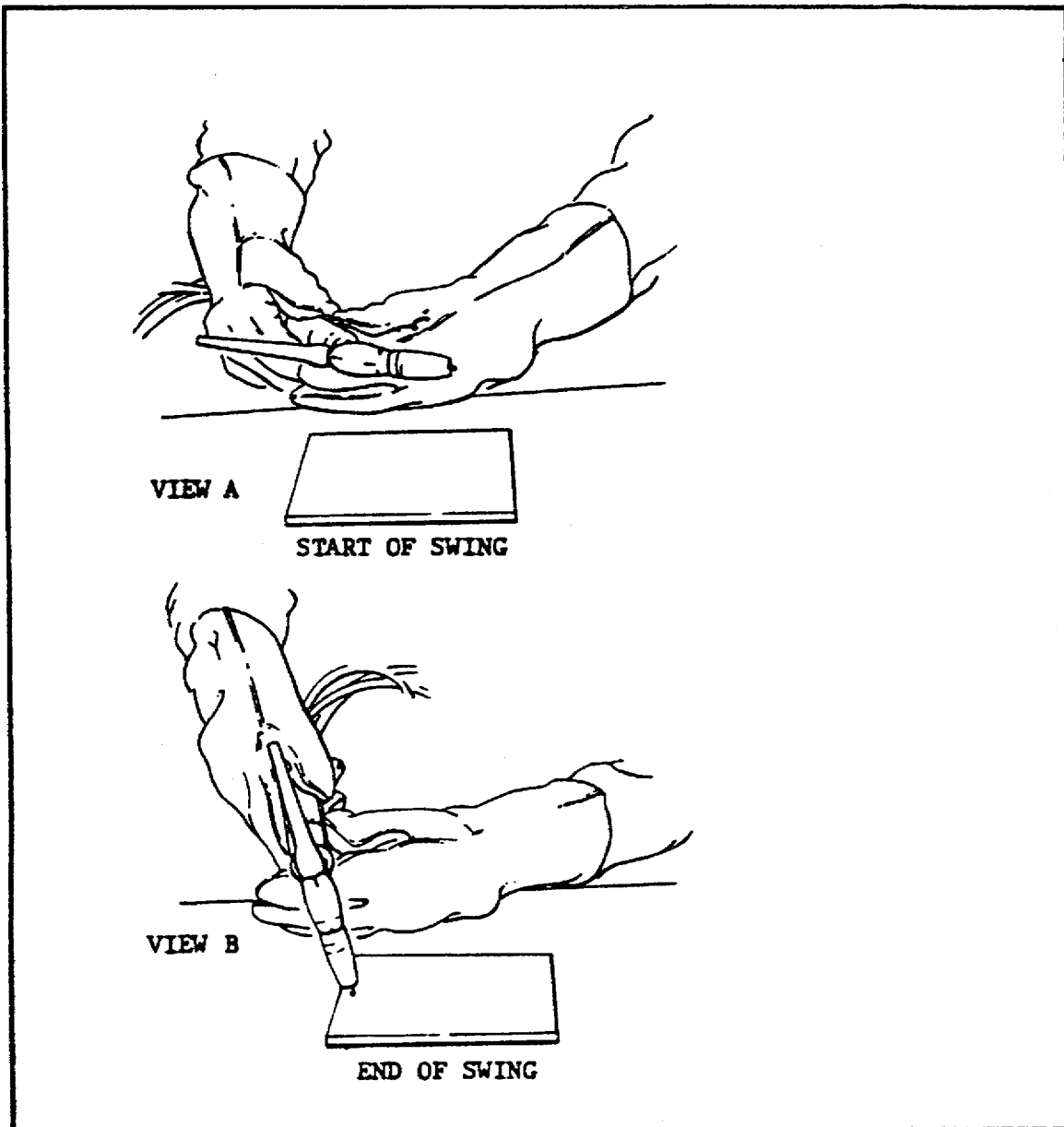

FIGURE 8. STARTING THE ARC

withdraw the electrode approximately one-eighth of an inch above the workpiece to avoid contaminating the electrode in the molten puddle.

1. *Welding Technique.*

(1) An initial arc can be struck on a starting block to heat the electrode. (The starting block can be a heavy piece of copper or of scrap steel. Do not use a carbon block for starting the arc, as the electrode becomes contaminated causing the arc to wander and become difficult to control.) After

WELDING OPERATIONS II - OD1654 - LESSON 1/TASK 1

striking the arc on a starting block, the arc is broken and reignited in the welding joint. This technique reduces the tendency for tungsten inclusions to occur at the start of the weld. When starting to weld with a hot electrode, rapidly move the torch in to the welding position, because the arc tends to strike before the torch is in the proper welding position. To stop the arc, snap the torch quickly back to the horizontal position. This motion must be made rapidly so that the arc will not mar or damage the weld surface or workpiece.

(2) Keep the arc short, about the same length as the diameter of the tungsten electrode being used. A short arc is essential to obtaining sufficient penetration of the weld into the base metal. It also prevents undercutting and excessive widening of the weld bead, which result in the loss of penetration control and weld contour. In addition, a short arc ensures that the inert gas completely shields and surrounds the weld as the weld is being formed.

(3) Establishing and maintaining a suitable weld metal pool is important and welding must not proceed ahead of the puddle. After a molten pool forms, move steadily along the seam with the gun positioned at an angle of between 60° and 90° to the plate; it should be pointed in the direction of the filler rod. Filler rod metal may be added to the front, or leading edge of the pool, but to one side of the center line. Both hands are moved in unison, with a slight backward and forward motion along the joint. The tungsten electrode should not touch the filler rod and the hot end of the filler rod should not be withdrawn from the argon shield.

(4) Thick sections that require multiple passes to form a suitable bead are best welded with an inert gas shielded arc using a consumable electrode. Sections of moderate thickness, between $1/16$ inch and $3/16$ inch thick, can be welded by any of the commercial processes available. Resistance spot welding or seam welding is used successfully on metals up to $3/16$ inch thick. Metal pieces up to $1/2$ inch thick may also be spot welded.

(5) When the arc is broken, shrinkage cracks may occur in the weld crater, resulting in a defective weld. This defect can be prevented by: gradually lengthening the arc while adding filler metal to

the crater; quickly breaking and restriking the arc several times while adding additional filler metal into the crater; or by using a foot control to reduce the current at the end of the weld. Tacking before welding is helpful in controlling distortion. Tack welds should be of ample size and strength, and should be chipped out or tapered at the ends before welding over.

5. Metal Inert Gas Electric Arc Welding

a. *General.*

(1) This welding process is relatively new and only recently has been adopted for use by the U.S. Army in the field. Much use of this welding process will be made in the repair of aluminum hull tracked vehicles.

(2) Gas metal-arc (MIG) welding is process in which a consumable, bare wire electrode, is fed into a weld at a controlled rate of speed. A blanket of inert gas (argon, helium, or a mixture of the two as used in TIG welding) shields the weld zone from contamination. This process produces high welds without the use of fluxes or the necessity of post cleaning the weld.

(3) The MIG welding unit is designed for manual welding with small diameter wire electrodes using a spool-on-gun torch as shown in figure 9 on the following page. (There are MIG welding systems that have the spool located away from the torch gun, but the principle of operation is the same as for the type system discussed here.) The complete system consisting of the torch, a voltage control box, and a welding contactor are shown in figure 10 on page 29. The torch handle contains a complete motor and gear reduction unit that pulls the welding wire electrode from a 4 inch diameter spool containing one pound of wire electrode mounted in the rear of the torch.

(4) Three basic sizes of wire electrode may be used: 3/32 inch; 3/64 inch; and 1/16 inch. Any type of metal may be welded, provided the welding wire electrode is of the same composition as the base metal.

(5) The unit is designed for use with an ac-dc conventional, constant-current type welding power supply. This means that the gasoline engine driven

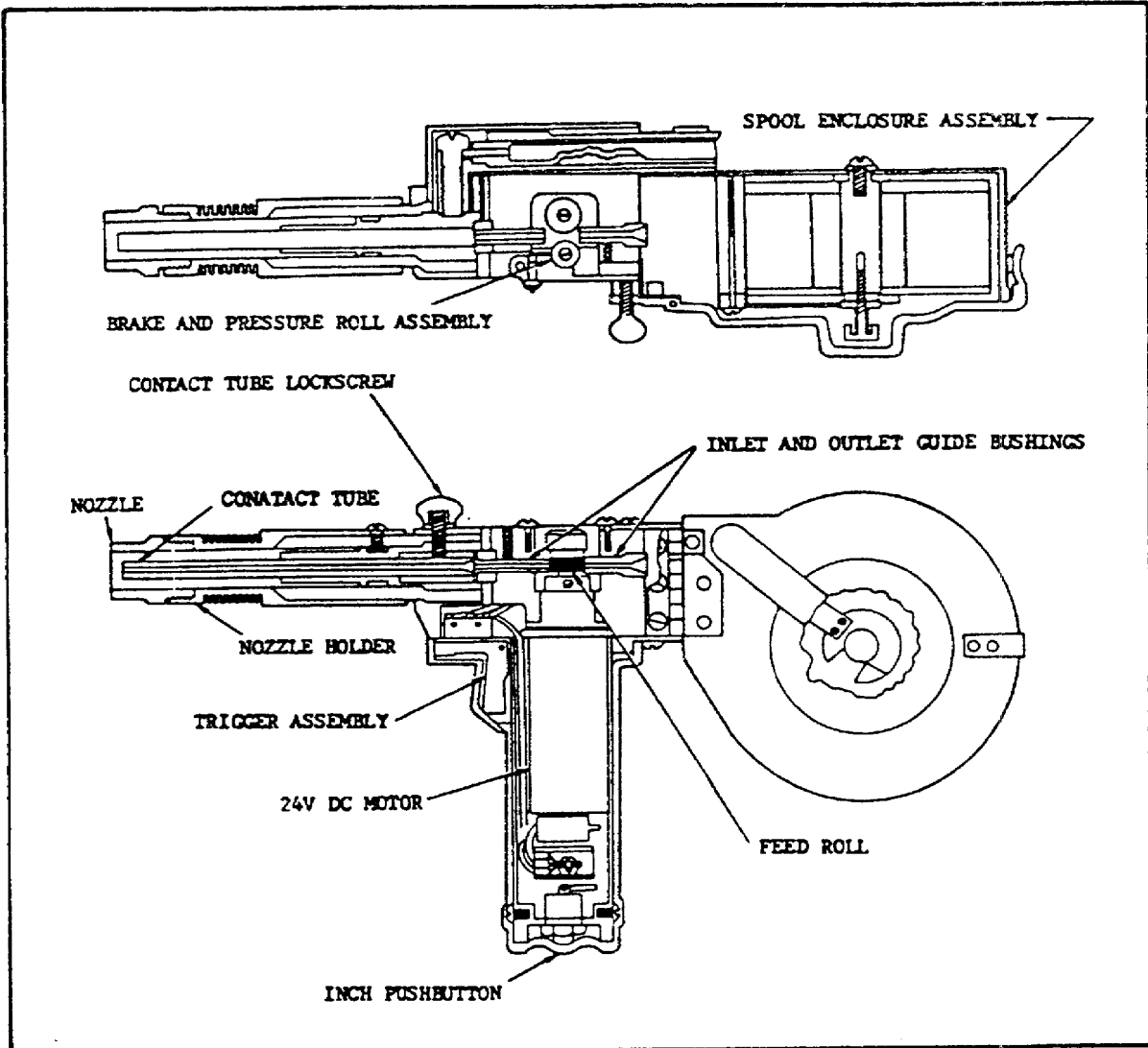

FIGURE 9. MIG WELDING TORCH.

arc welding machines issued to field units may be used as a power source and a welding source.

b. *MIG Welding Equipment Components.*

(1) *Contact Tube.* This tube is made of copper with a hole 0.01 to 0.02 inch larger than the electrode. The contact tube and guide bushings must be changed when changing the size of the electrode. Electric power is transmitted through the contact tube to the electrode. An insulated lock screw secures the contact tube in the torch.

(2) *Nozzle and Holder.* The nozzle is made of copper to dissipate heat and chrome-plated to reflect the heat. The holder is made of stainless steel and is connected to an insulating material

WELDING OPERATIONS II - OD1654 - LESSON 1/TASK 1

which prevents an arc from being drawn between the nozzle and ground in case the gun comes in contact with the work.

(3) *Inlet and Outlet Guide Bushings.* The bushings are made of nylon for longer wear. They must be changed to suit the wire electrode size when the electrode size is changed.

(4) *Pressure Roll Assembly.* This is a smooth roller, under spring tension, which pushes the wire electrode against the feed and allows the wire to be pulled from the spool. A thumbscrew applies tension as required.

(5) *Motor.* When the inch button is depressed, the current for running the motor comes from the 110 volt ac-dc source, and the motor pulls the wire electrode from the spool at the required rate of feed. The current for this motor is supplied by the welding generator.

(6) *Spool Enclosure Assembly.* This assembly is made of plastic which prevents arc spatter from jamming the wire electrode on the spool. A small window allows the operator to visually check the amount of wire electrode remaining on the spool.

NOTE

If for any reason the wire electrode stops feeding, a burn-back will result. With the trigger depressed, the welding contactor is closed, thereby allowing the welding current to flow through the contact tube. As long as the wire electrode advances through the tube, an arc will be drawn at the end of the wire electrode. However, should the wire electrode stop feeding while the trigger is still being depressed, the arc will then form at the end of the contact tube, causing it to melt off. This last action is called burn-back.

(7) *Welding Contactor.* The positive cable from the dc welding generator is connected to a cable coming out of the welding contactor, and the ground cable is connected to the workpiece. The electrode cable and the welding contactor cable are connected

WELDING OPERATIONS II - OD1654 - LESSON 1/TASK 1

between the welding contactor and the voltage control box. The electrode cable enters through the welding current relay and connects into the argon supply line. Both then go out of the voltage control box and into the torch as one line.

(8) *Argon Gas Hose.* This hose is connected from the voltage control box to the argon gas regulator on the argon cylinder.

(9) *Voltage Pickup Cable.* This cable must be attached to the ground cable at the workpiece; it serves to supply the current needed to operate the motor feeding the wire electrode through the torch.

(10) *Torch Switch and Grounding Cables.* The torch switch cable is connected into the voltage control box, and the torch grounding cable is connected to the case of the voltage control box. A complete MIG welding system is shown in figure 10 on the following page.

c. *Operating the MIG Torch.*

(1) *Starting the Weld.* To operate the torch, start by pressing the inch pushbutton on the torch handle to permit the wire electrode to emerge from the nozzle. The wire should extend one-half of an inch beyond the end of the nozzle. With the main line switch in the ON position, and the argon gas and power sources adjusted properly, the operator may begin to weld.

(2) If welding in the open air, a protective screen must be installed to prevent the argon gas from being blown away from the weld zone.

(3) Press the torch trigger; this permits current to flow through the torch switch cable and through the contactor cable, closing the contractor.

(4) When the contactor closes, the welding circuit from the generator to the welding torch is completed.

(5) At the same time as the contactor closes, the shielding gas solenoid valve opens, allowing a flow of argon gas to pass out of the nozzle to shield the weld zone.

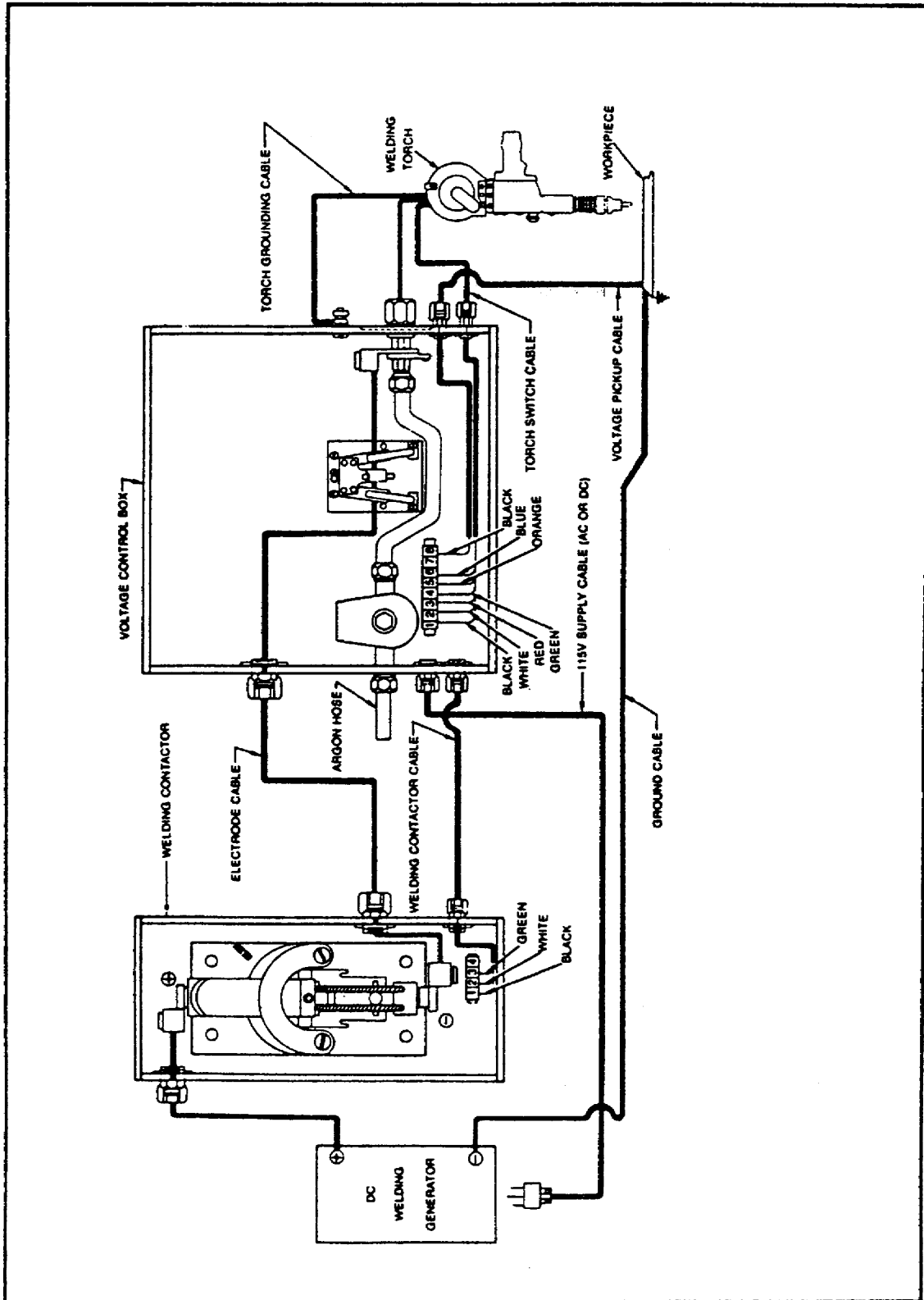

FIGURE 10. MIG WELDING SYSTEM.

WELDING OPERATIONS II - OD1654 - LESSON 1/TASK 1

(6) Lower the welding helmet and touch the end of the wire electrode to the workpiece. The gun is held at a 90° angle to the work but pointed at a 100 angle toward the line of travel.

(7) Welding will continue as long as the arc is maintained and the trigger is depressed.

CAUTION

To prevent overloading the torch motor when stopping the arc, release the trigger; never snap the arc out by raising the torch without first releasing the trigger.

d. *Setting the Wire Electrode Feed.*

(1) A dial on the front of the voltage control box, labeled WELDING CONTROL, is used to regulate the speed of the wire electrode feed.

(2) To increase the speed of the wire electrode being fed from the spool, turn the dial counterclockwise. This decreases the amount of resistance across the arc and allows the motor to turn faster. Turning the dial clockwise will increase the amount of resistance, thereby decreasing the speed of the wire electrode being fed from the spool.

(3) At the instant that the wire electrode touches the workpiece, between 50 and 100 volts direct current is generated. This voltage is picked up by the voltage pickup cable and shunted back through the voltage control box into a transformer. The transformer steps down the voltage to 24 volts direct current for operation of the torch motor.

e. *Fuses.*

(1) Two 10 ampere fuses, located at the front of the voltage control box, protect and control the electrical circuit within the voltage control box.

(2) A one ampere fuse, located on the front of the voltage control box, protects and controls the torch motor.

f. *Installing the Wire Electrode.*

(1) Open the cover to the spool enclosure, and the brake and pressure roll assemblies shown in figure 9 on page 26.

(2) Unroll and straighten six inches of wire electrode from the top of the spool.

(3) Feed this straightened end of the wire electrode into the inlet and outlet bushings; then place the spool on the mounting shaft.

(4) Close the pressure roller, and secure it in place. Press the inch button, feeding the wire electrode until there is one-half of an inch protruding beyond the end of the nozzle.

g. *Setting the Argon Gas Pressure.*

(1) Flip the argon switch on the front of the voltage control panel to the MANUAL position.

(2) Turn on the argon gas cylinder valve, and set the pressure on the regulator.

(3) When the proper pressure is set on the regulator, flip the argon switch to the AUTOMATIC position.

(4) When the argon switch is placed in the MANUAL position, the argon gas continues to flow until it is turned off at the valve. When in the AUTOMATIC position, the argon gas flows only when the torch trigger is depressed and stops flowing when the torch trigger is released.

h. *Generator Polarity.* For proper operation of the torch motor, the generator must be set on reverse polarity. If the generator is set on straight polarity, the torch motor will run in reverse, withdrawing the wire electrode from the torch gun and causing severe burn-back of the torch.

i. *Reclaiming Burn-Back Contact Tubes.* When the contact tubes are new, they are 5 3/8 inches long. When burn-back occurs, a maximum of 3/8 inch may be filed off. File a flat spot on top of the guide tube, then use an appropriate size drill pilot and

WELDING OPERATIONS II - OD1654 - LESSON 1/TASK 1

drill to drill out the contact tube. Example: for a 3/64 inch contact tube, use a Number 46 or 47 drill bit.

j. *Welding Operations.* Any of the ferrous and nonferrous metals can be welded through the use of the MIG welding process. The hard-to-weld metals, such as aluminum, magnesium, and titanium are best welded with either the MIG or the TIG welding processes. The MIG welding process uses a filler rod and is used for welding thicker metal, particularly thick aluminum. The TIG welding process is used for welding thinner metal, with or without the use of a filler rod. The preparation of the metal and the type of joints used in MIG welding operations are the same as or are modifications of the five basic joints discussed in paragraph 4g beginning on page 14. A more detailed discussion of these five basic joints is contained in TM 9-237.

6. Conclusion

This task described the principles, operations, equipment nomenclature, and safety precautions pertaining to the tungsten inert gas and gas metal-arc welding processes. These are two newly developed welding processes that have recently been adopted for use by the U.S. Army in the field. The next task describes the procedures for troubleshooting and repairing welding equipment.

WELDING OPERATIONS II - OD1654 - LESSON 1/TASK 2

LESSON 1

INERT GAS WELDING PRINCIPLES, EQUIPMENT, AND SAFETY PRECAUTIONS; GAS METAL-WELDING PRINCIPLES, OPERATIONS, AND EQUIPMENT NOMENCLATURE; AND PROCEDURES FOR TROUBLESHOOTING WELDING EQUIPMENT AND DETERMINING METHODS OF REPAIR

TASK 2. Describe the procedures for troubleshooting welding equipment and determining methods of repair.

CONDITIONS

Within a self-study environment and given the subcourse text, without assistance.

STANDARDS

Within two hours

REFERENCES

No supplementary references are needed for this task.

1. Introduction

The previous task served to describe two recently developed welding processes, tungsten inert gas (TIG) and gas metal-arc (MIG), which have recently been adopted for use by the U.S. Army in the field. These processes provide intermediate direct support (IDS) and intermediate general support (TGS) units with the capability for welding the hard-to-weld metals such as aluminum, magnesium, and titanium. But, the performance of maintenance on welding equipment is essential to maintaining this welding capability. The welder is responsible for the performance of operator maintenance. The repair shop technician is responsible for ensuring the performance of operator maintenance on this equipment. Maintenance functions beyond the capabilities of the operator are performed by the unit and mission maintenance shops. These maintenance functions, consisting of

WELDING OPERATIONS II - OD1654 - LESSON 1/TASK 2

troubleshooting and repair, are described in subsequent paragraphs only for oxyacetylene and inert gas welding equipment.

2. Oxyacetylene Welding Equipment

a. *General.* It is understood that both stationary and portable oxyacetylene welding equipment exist. However, this paragraph describes only the portable oxyacetylene welding equipment, shown in figure 11 on the following page, which is allocated to IDS and IGS units in the field. The portable oxyacetylene welding outfit consists of an oxygen cylinder and an acetylene cylinder with attached valves, two regulators, two sets of gages, and two lengths of hose. This equipment may be temporarily secured on the floor, or mounted in a two-wheel all welded steel truck equipped with a platform which will support two large size cylinders. The cylinders are secured by chains attached to the truck frame. A metal box welded to the frame provides for storage of the cutting torch, tips, sparklighter, gloves, fluxes, goggles, and necessary wrenches.

b. *Oxygen Cylinder.*

(1) *General.* A protective cap screws onto the valve, at the top of the cylinder, to prevent it from being damaged during shipment, handling, or when being used. During welding operations, open the oxygen cylinder valve slowly to prevent damage to the regulator high-pressure gage mechanism. Be sure that the regulator tension screw is released before opening the valve. When the oxygen cylinder is not in use, the valve should be closed and the protecting cap screwed on to prevent damage to the valve.

(2) *Troubleshooting and Repair.* Listed below is the correct procedure that should be followed for troubleshooting and repair of the oxygen cylinder; specifically the malfunction: VALVE IS DEFECTIVE.

Step 1. If the valve is defective and will not open, do not use a hammer or wrench to open the valve. Instead, mark the cylinder and set it aside for return to the supplier.

Step 2. Whenever the threads on the valve connections are damaged to a degree that will prevent proper assembly to the regulator, no repair

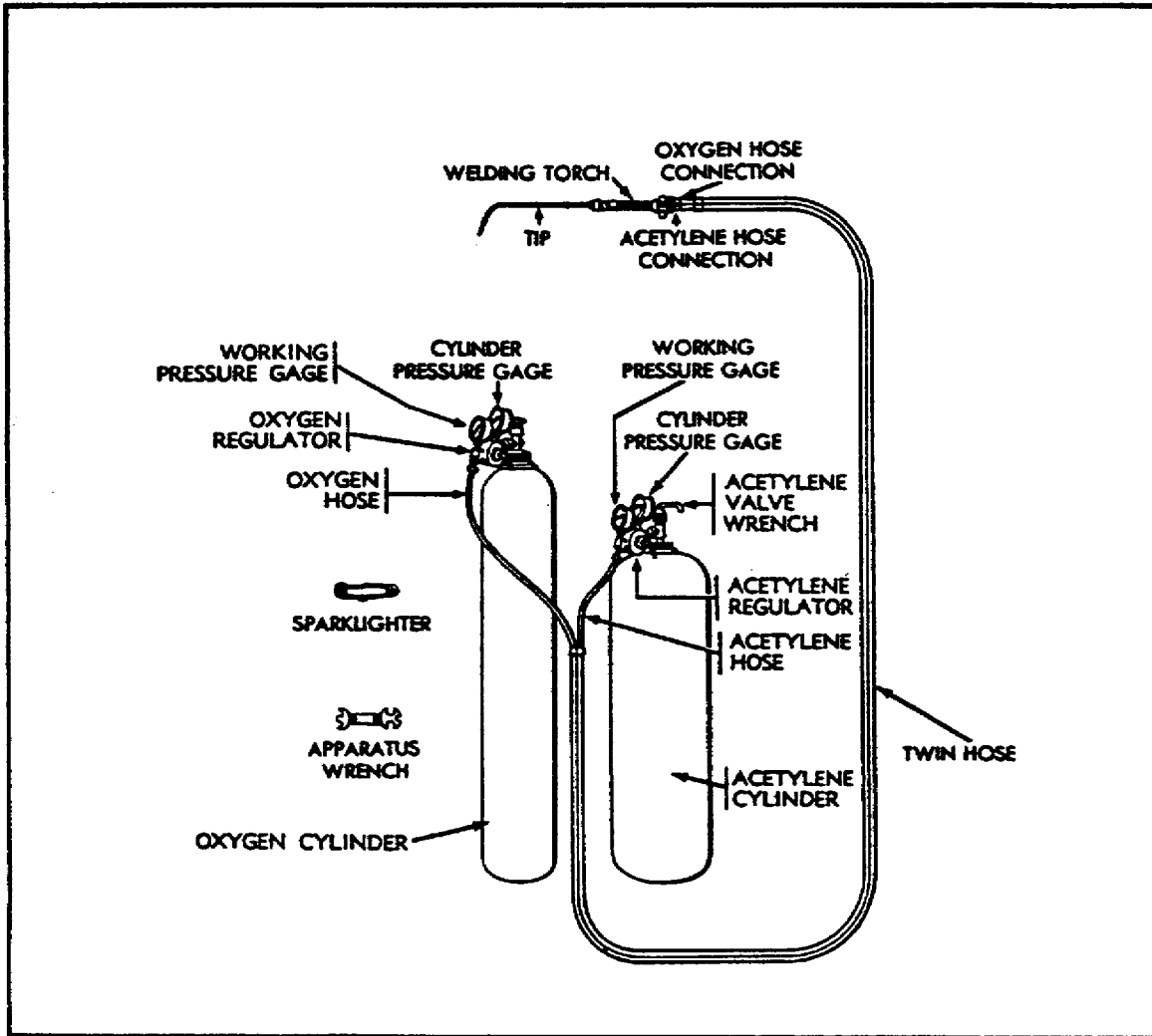

FIGURE 11. PORTABLE OXYACETYLENE WELDING EQUIPMENT.

should be attempted. Instead, mark the cylinder and set it aside for return to the supplier.

c. *Acetylene Cylinder.*

(1) *General.* A protective cap screws onto the valve at the top of the cylinder, to prevent it from being damaged during shipment, handling, or when being used.

CAUTION

Because acetylene, accumulated in a confined space is a fire and explosion hazard, all acetylene cylinders should be checked for leakage at the valves and safety plugs before storing. Never test

WELDING OPERATIONS II - OD1654 - LESSON 1/TASK 2

for acetylene leaks with an open flame. Test all joints with soapy water. Should a leak occur around the valve stem of the cylinder, close the valve and tighten the packing nut. Cylinders leaking around the fuse plug should be taken outdoors away from all fires and sparks, and the contents wasted by slightly opening the valve. When returning empty cylinders, ensure that the valves are closed and the protective cap is secured in place to prevent escape of residual acetylene or acetone solvent.

(2) *Troubleshooting and Repair.* The troubleshooting and repair procedures for the acetylene cylinder defective valves are identical to those for the oxygen cylinder mentioned in paragraph 2b(2) on page 34. Listed below is the correct procedure that should be followed for troubleshooting and repair of the acetylene cylinder; specifically the malfunction: VALVE IS CLOGGED WITH ICE.

Step 1. Move the acetylene cylinder inside a well-ventilated building.

Step 2. Use warm water to thaw out the clogged up valve. Do not use scalding water or an open flame.

d. *Regulators* (figure 12 on the following page).

(1) *General.* The gases compressed in oxygen and acetylene cylinders are at pressures too high for oxyacetylene welding; therefore, regulators are necessary to produce working pressures and to control the flow of gases from the cylinders. Most regulators in use are of either the single-stage or the two-stage type. Single-stage regulators reduce the gas pressure to working pressures in one step, two-stage regulators perform the reduction to a working pressure in two steps. In either case, check valves should be installed between the torch hoses and the regulator to prevent flashback through the regulator. A single-stage oxygen regulator is shown in figure 12. The acetylene regulator is of the same general design as the oxygen regulator but will not withstand such high pressures. However, the troubleshooting and repair procedures for the acetylene regulator are the same as for the oxygen regulator.

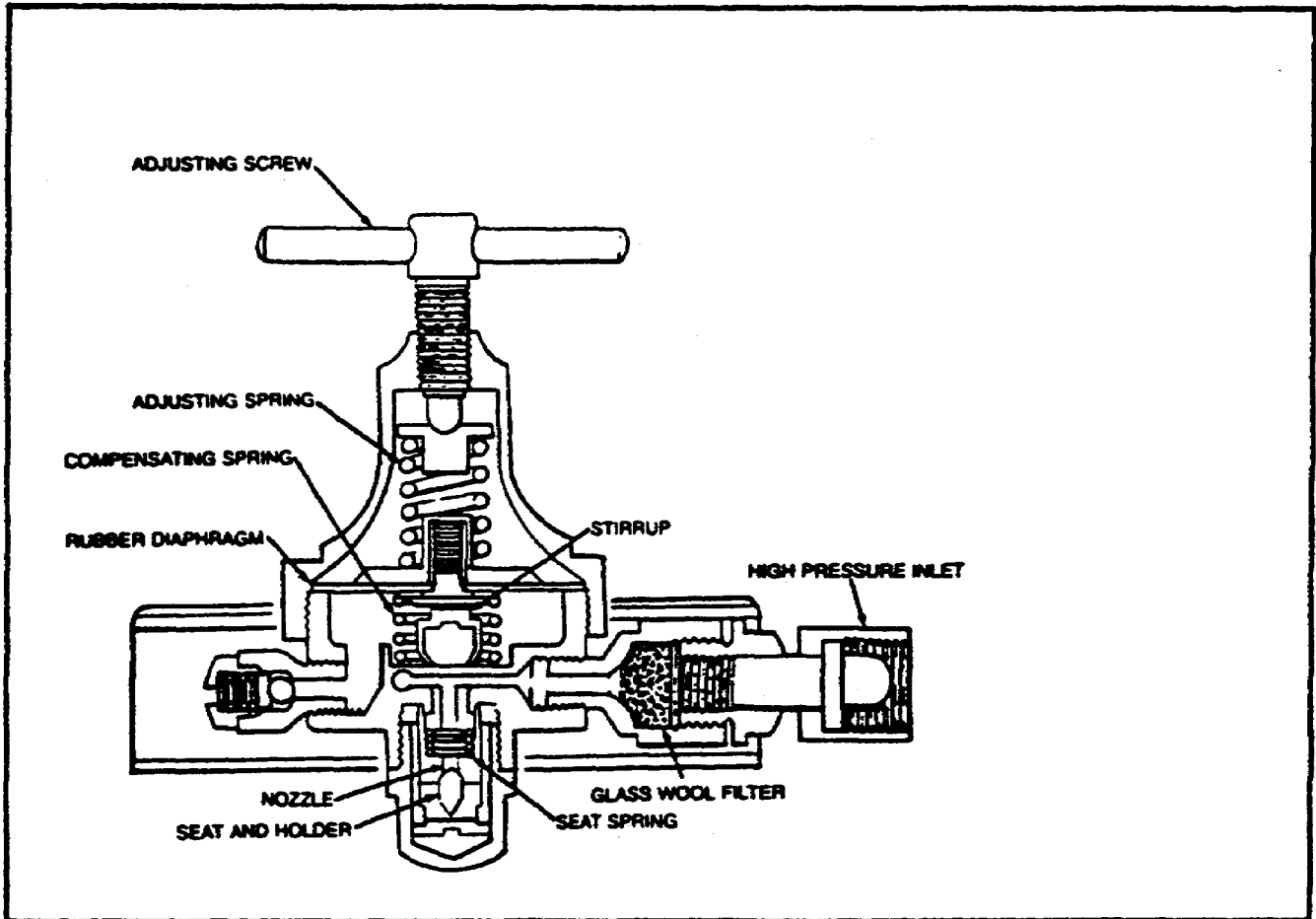

FIGURE 12. REGULATOR.

(2) *Troubleshooting and Repair.* Below are the correct repair procedures that maintenance personnel would follow for troubleshooting and repair of the regulator; specifically the malfunction: LEAKAGE OF GAS BETWEEN THE REGULATOR SEAT AND THE NOZZLE. (These troubleshooting and repair procedures are applicable to both the single- and two-stage regulators.)

WARNING

Leaking acetylene regulators are particularly dangerous because they present a definite explosive hazard.

Step 1. Leakage of gas between the regulator seat and the nozzle is the principal trouble encountered with regulators. It is indicated by a gradual increase in the pressure on the pressure gage when the adjusting screw is fully released or is in the adjusted position. This defect, called "creeping regulator," is caused by bad valve seats or by foreign matter lodged between the seat and the

WELDING OPERATIONS II - OD1654 - LESSON 1/TASK 2

nozzle. Remove and replace the seat if it is worn, cracked, or otherwise damaged.

Step 2. If the malfunction is caused by fouling with dirt or other foreign matter, clean the seat and nozzle thoroughly and blow out any dust or dirt in the valve chamber.

Step 3. Gages with defective bourbon tubes should be removed and replaced by new gages because satisfactory repairs cannot be made without special equipment. Defective bourbon tubes in the gages can be detected by the improper action of the gages or by escaping gas from the gage case.

Step 4. Broken or buckled gage tubes and distorted or buckled diaphragms are usually caused by a backfire at the torch, leaks across the regulator seats, or by failure to release the regulator adjusting screw fully before opening the cylinder valves. A buckled or distorted diaphragm cannot be adjusted properly and should be replaced with a new one. A rubber diaphragm can be replaced easily by removing the spring case through the use of a vise or wrench. Metal diaphragms are sometimes soldered to the valve case and their replacement can be done only by the manufacturer.

e. *Welding Torch* (figure 13 on the next page).

(1) *General*. The improper functioning of welding torches is usually due to leaking valves, leaks in the mixing head seat, scored or out-of-round welding tip orifices, clogged tubes or tips, and damaged inlet connection threads. Subsequent paragraphs describe the troubleshooting and repair procedures for three of these malfunctions.

WARNING

A leaking oxyacetylene welding torch should be repaired immediately, since it may result in a flashback or backfire, causing injury to personnel and/or damage to the welding equipment

(2) *Troubleshooting and Repair*.

(a) Listed below is the correct procedure that should be followed for troubleshooting and repair of the torch; specifically the malfunction: LEAKING VALVES.

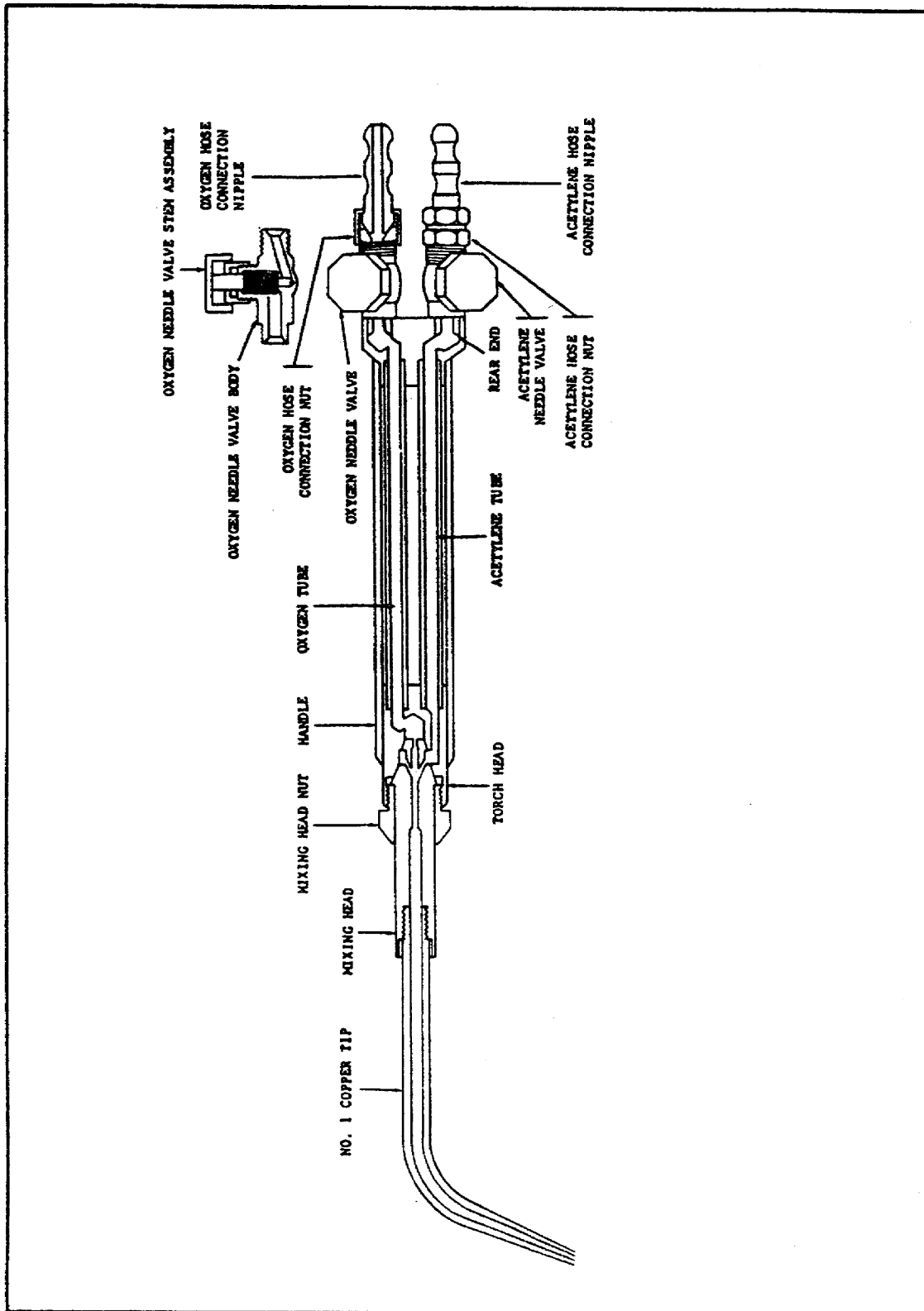

FIGURE 13. WELDING TORCH.

WELDING OPERATIONS II - OD1654 - LESSON 1/TASK 2

Step 1. Leaking valves are caused by worn or bent valve stems, damaged seats, or a combination of both, and should be refaced or replaced.

Step 2. Valves may also leak as a result of loose or worn packing. Leaks caused by loose packing may be corrected by tightening the packing nut. Worn packing must be replaced with new packing, then tightening the packing nut.

(b) Below is the correct procedure that would be followed for troubleshooting and repair of the torch; specifically the malfunction: LEAKS IN THE MIXING HEADS. (This condition is indicated by the popping out of the flame and by emission of sparks from the tip, accompanied by a squealing noise. Leaks in the mixing head will cause improper mixing of the oxygen and acetylene which will cause flashbacks, i.e., ignition and burning of the gases back of the mixing head in the torch tubes. A flashback causes the torch head and handle to suddenly become very hot. This defect is corrected by reaming out and trueing the mixing head seat.)

WARNING

Reaming out and trueing the mixing head seat should be done by the manufacturer because special reamers are required for trueing the seats.

(c) *Troubleshooting and Repair.* Listed below is the correct procedure that should be followed for troubleshooting and repair of the torch; specifically the malfunction: CLOGGED TIPS AND TUBES.

Step 1. This condition is the result of carbon deposits caused by flashbacks, or backfire, or by the presence of foreign matter that has entered the tubes through the hoses. If the tubes or tips are clogged, greater working pressures will be needed to produce the flame required for a given tip. The flame produced will be distorted. To correct this condition, the torch should be disassembled so that the tip, mixing head valves, and hose can be cleaned and blown out with compressed air at a pressure of 20 to 30 psi.

Step 2. The tip and mixing head should be cleaned either with a cleaning drill of the proper size or with soft copper or brass wire, and then blown out with compressed air. The cleaning drills should be approximately one drill size smaller than the tip orifice.

3. Electric Arc Welding Equipment

a. *General.* Electric arc welding equipment includes that equipment used for metal-arc, gas tungsten arc (TIG) and metal inert gas (MIG) welding operations. This equipment is contained in the Welding Shop, Trailer Mounted, Model 491996, which is allocated to IDS and IGS maintenance units in the field. This shop set provides the unit with the capability to perform oxycetylene welding and cutting; shielded metal arc welding; gas metal arc welding; flux core arc welding; gas tungsten arc welding; and metal air carbon arc cutting. The welding shop tool boxes contain all of the equipment necessary to perform these welding and cutting operations, and the necessary handtools. The following paragraph describes the troubleshooting and repair procedures for the welding machine, which is the electrical power source, and for the MIG welding gun and wire feeder.

b. *Welding Machine Model: DCC-353-P, figure 14.*

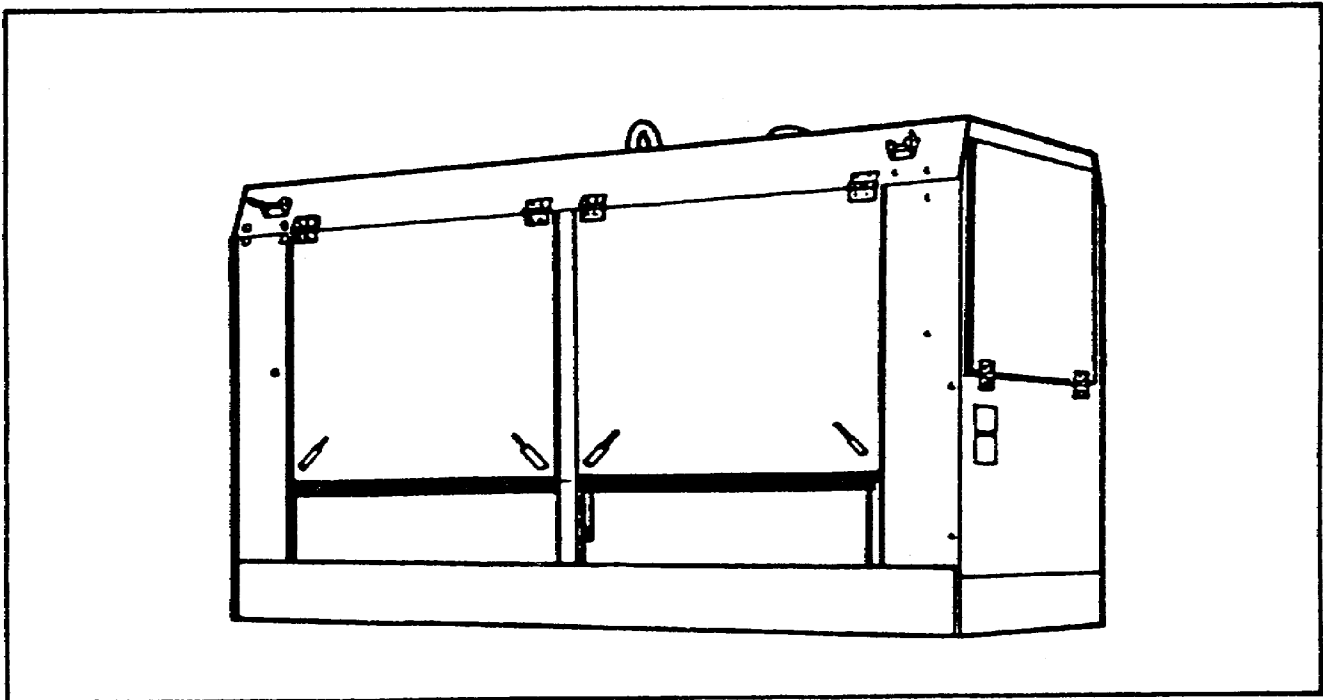

FIGURE 14. WELDING MACHINE.

WELDING OPERATIONS II - OD1654 - LESSON 1/TASK 2

(1) *General.* This welding machine, also referred to as the welding generator, has a 350 ampere, constant current/constant voltage, diesel engine driven generator, and is a self-contained unit mounted on a welded steel frame. The unit is a single-operator system designed for constant current or constant voltage welding. The unit is covered by a sheet metal canopy bolted directly to the frame. The control panel is at the generator end of the unit. The engine used in this unit is a water-cooled industrial diesel engine. It is directly coupled to the welding generator shaft by a flexible coupling. The following subparagraphs describe the operation, and troubleshooting and repair procedures for one malfunction of the welding generator.

(2) *Operation.*

(a) *IGNITION Switch* (1) (figure 15 on the following page). The diesel engine starter motor is actuated by this switch. The engine should not be cranked for more than 15 seconds continuously. If it is necessary to crank the engine more than one time, check the starter motor for temperature. Allow the starter motor to cool before energizing again.

(b) *THROTTLE* (2). This control varies the engine speed. When the throttle is fully pushed in, the engine operates at an idle, and when the throttle is fully pulled out, the engine runs at an operating speed of 1800 rpm (revolutions per minute). The throttle may be locked in any position by twisting 1/4 turn clockwise. To unlock, twist counterclockwise.

(c) *ETHER START Pushbutton* (3). This pushbutton activates an aerosol container of diesel engine starting solution. The ether solution is injected into the intake manifold of the diesel engine to aid in starting.

(d) *OIL PRESSURE Gage* (4). This gage indicates the oil pressure of the engine. The scale is 0 to 75 psi. At 1800 rpm, the oil pressure should read 38 to 43 psi after the engine is at operating temperature.

(e) *WATER TEMPERATURE Gage* (5). This gage indicates the temperature of the engine coolant. The most efficient operating temperature of the

engine is 195° to 210° F. The engine temperature should not exceed 230° as the lubricating capability of the oil deteriorates rapidly above this temperature.

(f) *BATTERY AMMETER* (6) (figure 15). This meter indicates the charge or discharge current through the battery for all engine electrical requirements except for the starter. Under normal operating conditions, the *BATTERY AMMETER* should indicate 5 to 10 amperes positive. If the battery has been damaged or heavily discharged, the meter will indicate much greater current.

(g) *CONTROL Receptacle* (7). When the welding machine is used with a wire electrode feeder, the control and power connections to the wire feeder are made to this receptacle.

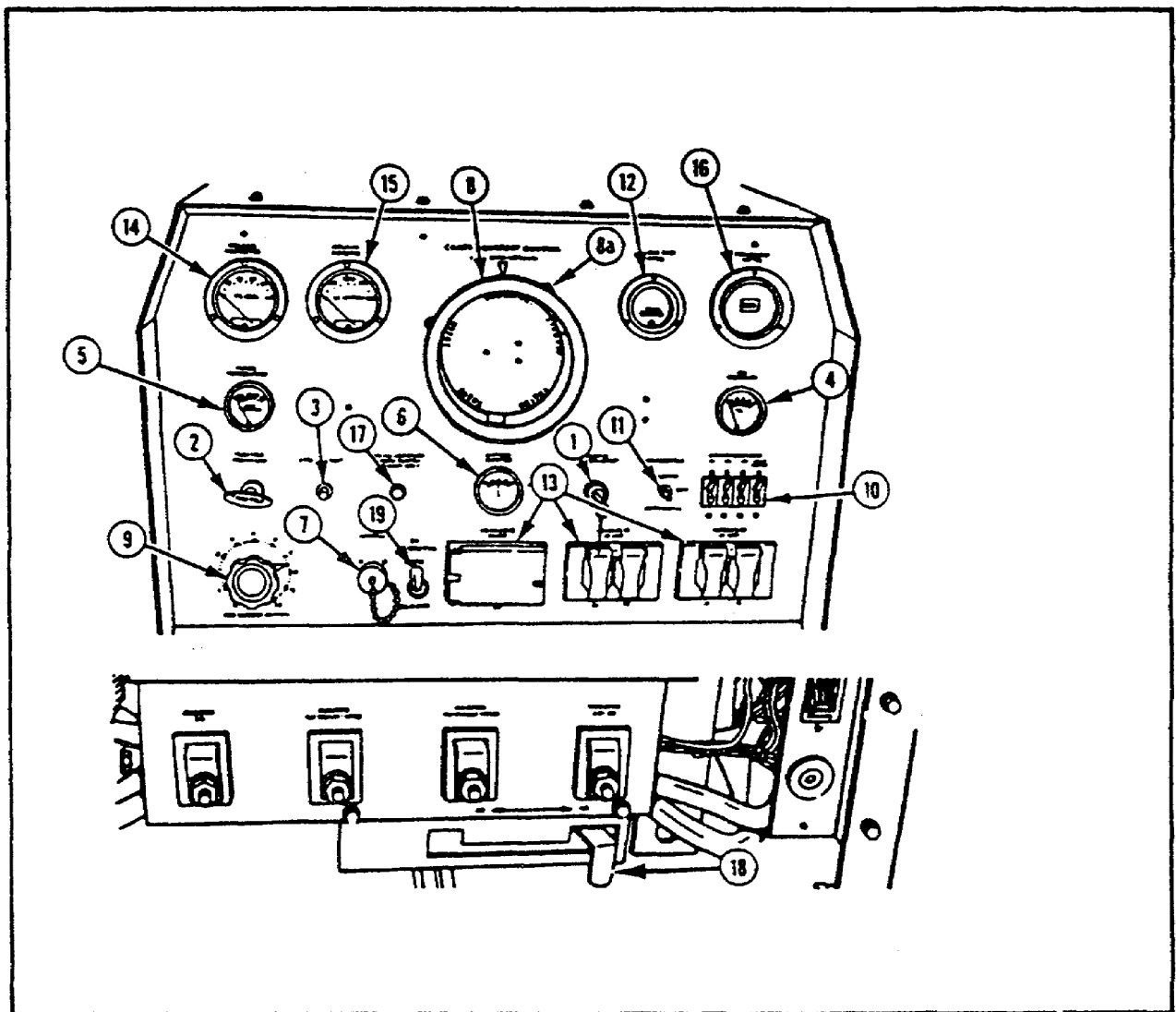

FIGURE 15. CONTROLS AND INSTRUMENTS.

CAUTION

If wire feeders are connected to this unit, be sure the electrical wiring and functions of such a unit are compatible, otherwise damage to the generator circuit and the wire feeder may occur.

(h) *COURSE CURRENT CONTROL* (8) (figure 15 on the previous page). This control has five detent current control positions and is used in the constant current mode only. Clockwise rotation increases current; counterclockwise rotation decreases current.

(i) *FINE CURRENT CONTROL* (9). This control operates in both constant current and constant voltage to permit finer adjustment of the welding current. Clockwise rotation increases welding current, and counterclockwise rotation decreases current.

(j) *CIRCUIT BREAKERS* (10). Four *CIRCUIT BREAKERS* protect the auxiliary/exciter circuit from overloads. One *CIRCUIT BREAKER* protects the main power. Two *CIRCUIT BREAKERS* protect the two standard duplex outlets, and the fourth protects the twistlock outlet.

(k) *IR COMPRESSOR MODE Switch* (11). This three-position (MANUAL, OFF and AUTOMATIC) switch controls the magnetic clutch which drives the air compressor.

(l) *RUNNING TIME Meter* (12). This meter registers the time the welding machine has been in operation. It is an aid in determining preventive maintenance procedures.

(m) *Auxiliary Power Outlets* (13). Two standard duplex outlets provide an auxiliary 115 volts and 15 amperes, and a single twistlock outlet provides auxiliary 115 volts and 20 amperes, both at 60 Hz (Hertz) alternating current.

(n) *WELDING VOLTMETER* (14). This meter indicates the available voltage as selected by the *FINE CURRENT CONTROL*.

WELDING OPERATIONS II - OD1654 - LESSON 1/TASK 2

(o) *WELDING AMMETER* (15) (figure 15 on page 43). This meter indicates the available amperage as selected by the *COURSE CURRENT CONTROL*.

(p) *FREQUENCY METER* (16). This meter indicates the power output of the welding machine for use of the 115 volts alternating current auxiliary power requirements.

(q) *LOW OIL PRESSURE BYPASS Switch* (17). This pushbutton switch disengages the low oil pressure sensor to allow the engine to start.

(r) *MODE SELECTOR Switch* (18). This switch is used to select either constant current (CC) or constant voltage (CV) welding modes.

(s) *CV CONTACTOR Switch* (19). This two-position switch closes the welding machine contactor assembly. The switch must be in the *CLOSE* position when the welding machine is used in conjunction with inert gas shielded welding sets (MIG) which have an integral control assembly. The switch should be in the *OPEN* position when welding in other modes.

(3) *Troubleshooting and Repair*. Listed below are the troubleshooting and repair procedures that should be followed for repair of the welding generator, specifically the malfunction: *ENGINE OPERATES BUT THERE IS NO POWER OUTPUT FROM THE WELDING GENERATOR*.

Step 1. Check for defective fuse. If the fuse is defective, replace the fuse as follows: (Refer to figure 16 on the following page.)

(a) Open the left side rear door (1) of the welding generator.

(b) Twist and remove the fuse holder (2) on the control box (3) mounted on the rear of the lower panel (4).

(c) Remove the unserviceable fuse from the fuse holder (2).

(d) Procure a new fuse and install it in the reverse order of removal of the defective fuse.

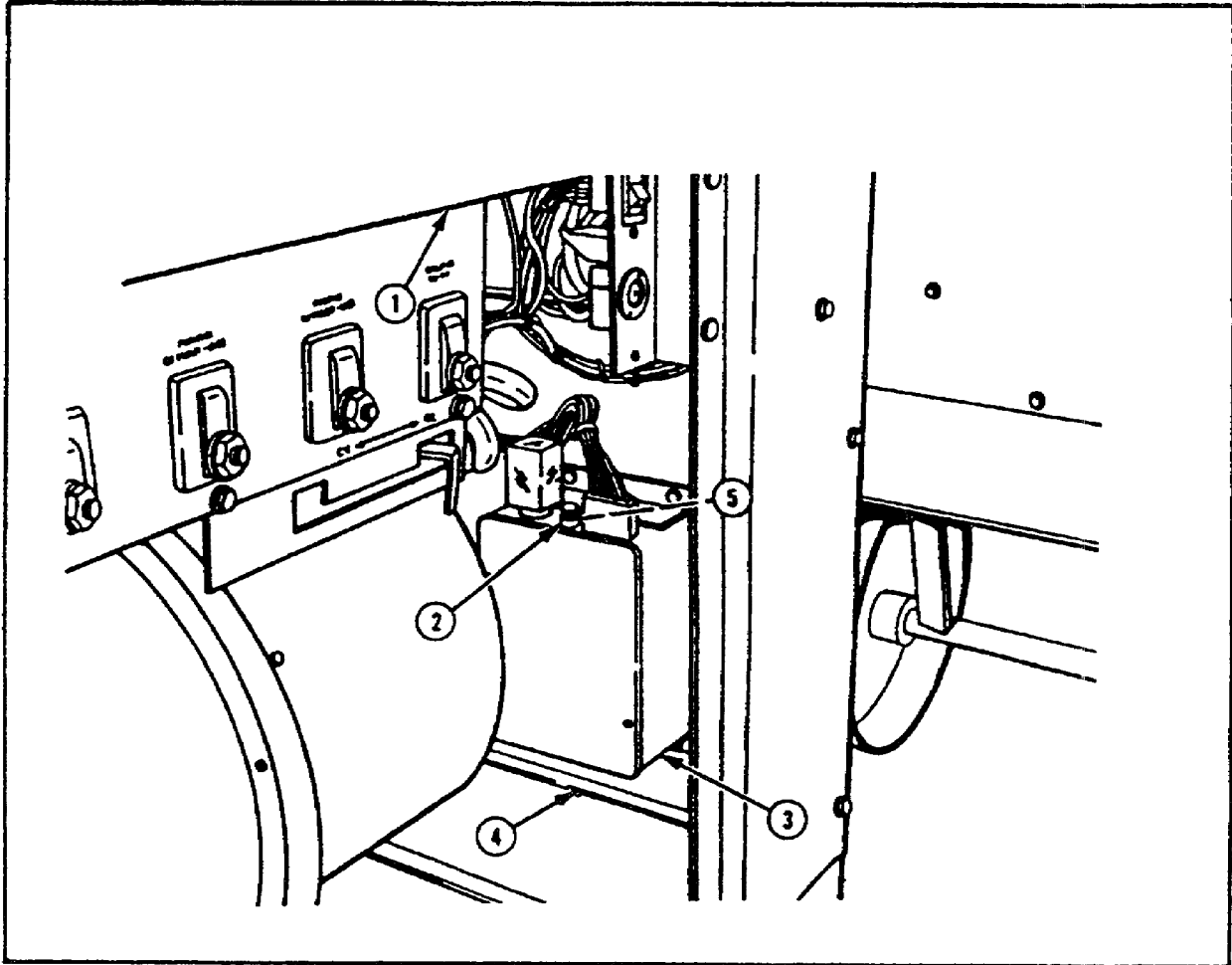

FIGURE 16. LEFT REAR SIDE OF WELDING GENERATOR.

Step 2. Check for and tighten all loose cable connections.

Step 3. Check for dirty or defective generator brushes. If brushes are dirty or defective, replace them as follows: (Refer to figure 17 on the following page.)

(a) It is assumed that the lower panel (4) has been removed to provide access to the brush rack (3).

(b) Tag and remove the wire leads from the brush rack caps (5).

(c) Remove two bolts (1), two lockwashers (2), and the brush rack (3) from the housing (4a).

(d) Unscrew and remove the brush rack caps (5).

(e) Push the brushes (6) up and out of the brush rack (3).

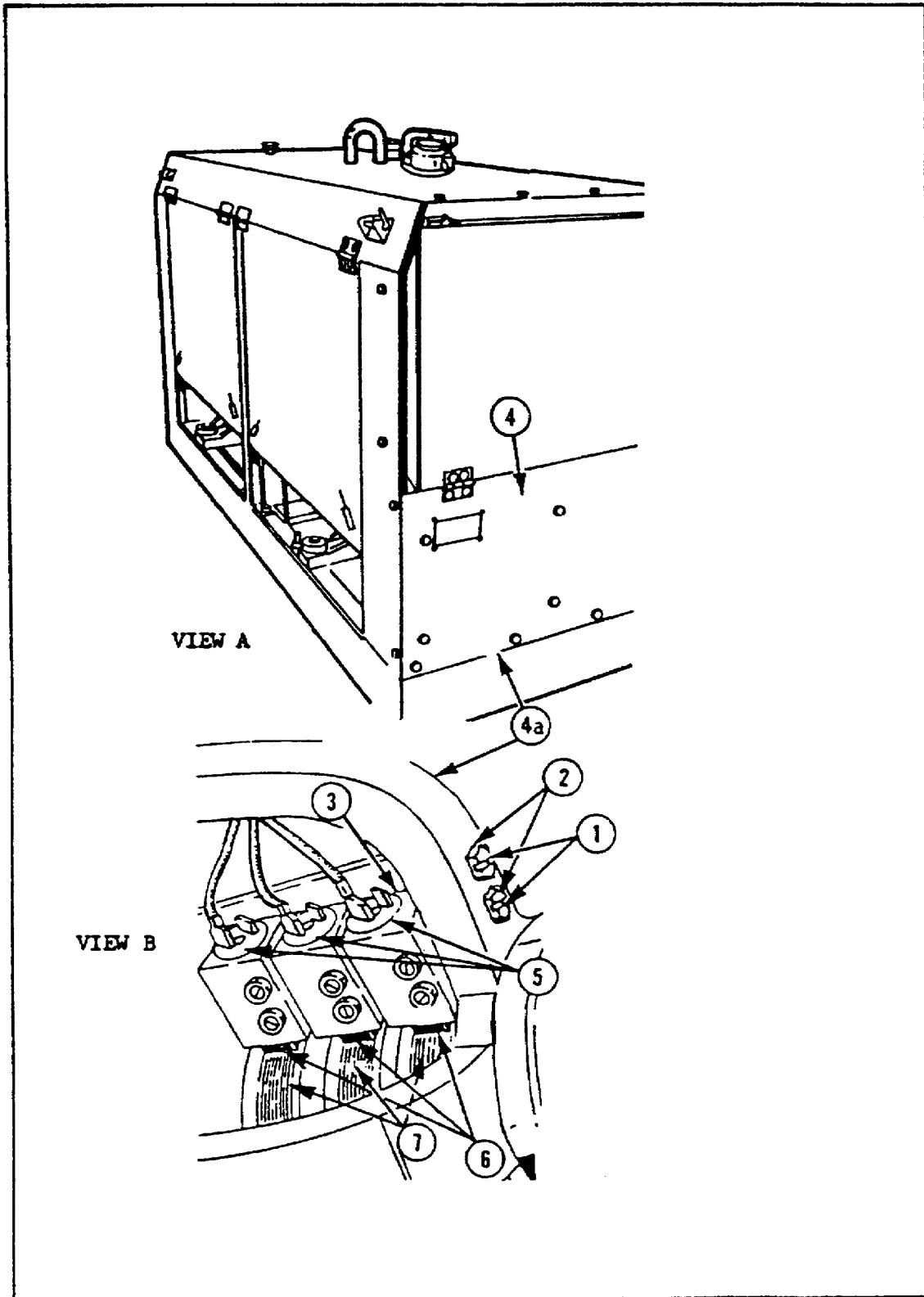

FIGURE 17. LOWER PANEL AND BRUSHES.

WELDING OPERATIONS II - OD1654 - LESSON 1/TASK 2

(f) Procure new brushes and install them in the reverse order of removal.

(g) Fit the new brushes (6) (figure 17 on the previous page) to the sliprings (7) by inserting strips of Number 00 sandpaper, smooth side down, between the slipring and the brushes.

(h) Pull the sandpaper from one end in the direction of the slipring rotation, while holding the other end of the sandpaper with the other hand to avoid pulling it out completely. Pull the sandpaper back to its original position, in the opposite direction, and lift the brush on each return stroke. Continue drawing the sandpaper back and forth as described until the brushes have the same curvature as the sliprings.

(i) Blow out all carbon dust with compressed air having a pressure not to exceed 25 psi.

Step 4. Check for defective COURSE CURRENT CONTROL. If the COURSE CURRENT CONTROL is defective, replace it as follows: (Refer to figure 15 on page 43.)

(a) It is assumed that the upper panel has been removed to provide access to the COURSE CURRENT CONTROL electrical connections behind the panel.

(b) Tag and remove all electrical leads to the COURSE CURRENT CONTROL.

(c) Remove COURSE CURRENT CONTROL from the upper panel by removing three screws from around the COURSE CURRENT CONTROL.

(d) Procure and install a new COURSE CURRENT CONTROL onto the upper panel in the reverse order of removal.

Step 5. Check for shorted or open armature windings. If defective, replace the armature assembly as follows: (Refer to figure 18 on the following page.)

(a) It is assumed that the exciter stator assembly (9) has been removed to provide access for checking the armature windings and replacing the armature assembly.

(b) Remove two screws (1) and plate (2) from the fan coupling housing (3).

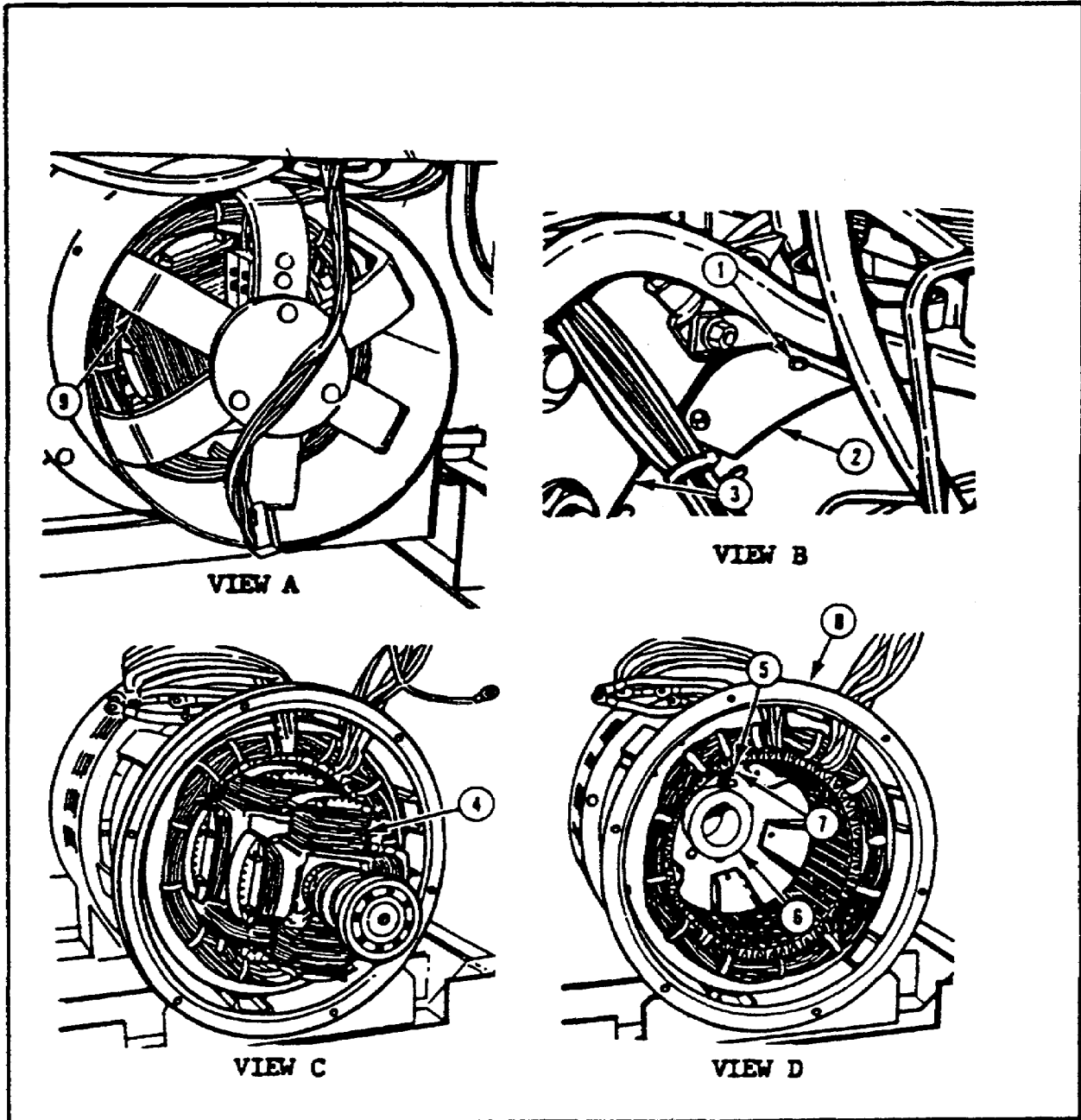

FIGURE 18. EXCITER STATOR AND ARMATURE ASSEMBLIES.

(c) Turn the armature assembly (4) until the two setscrews (5) holding the shaft of the armature assembly in the coupling (6) are accessible.

(d) Loosen the two jamnuts (7) and two setscrews (5).

(e) Remove the armature assembly (4) from inside the field coil assembly housing (8) using a sling and suitable lifting device.

WELDING OPERATIONS II - OD1654 - LESSON 1/TASK 2

(f) Procure and install a new armature assembly into the field coil assembly housing in the reverse order of removal.

Step 6. Check for an open or shorted field coil assembly and mode selector switch. If defective, replace them as follows: (Refer to figures 19 below and 20 on the following page.)

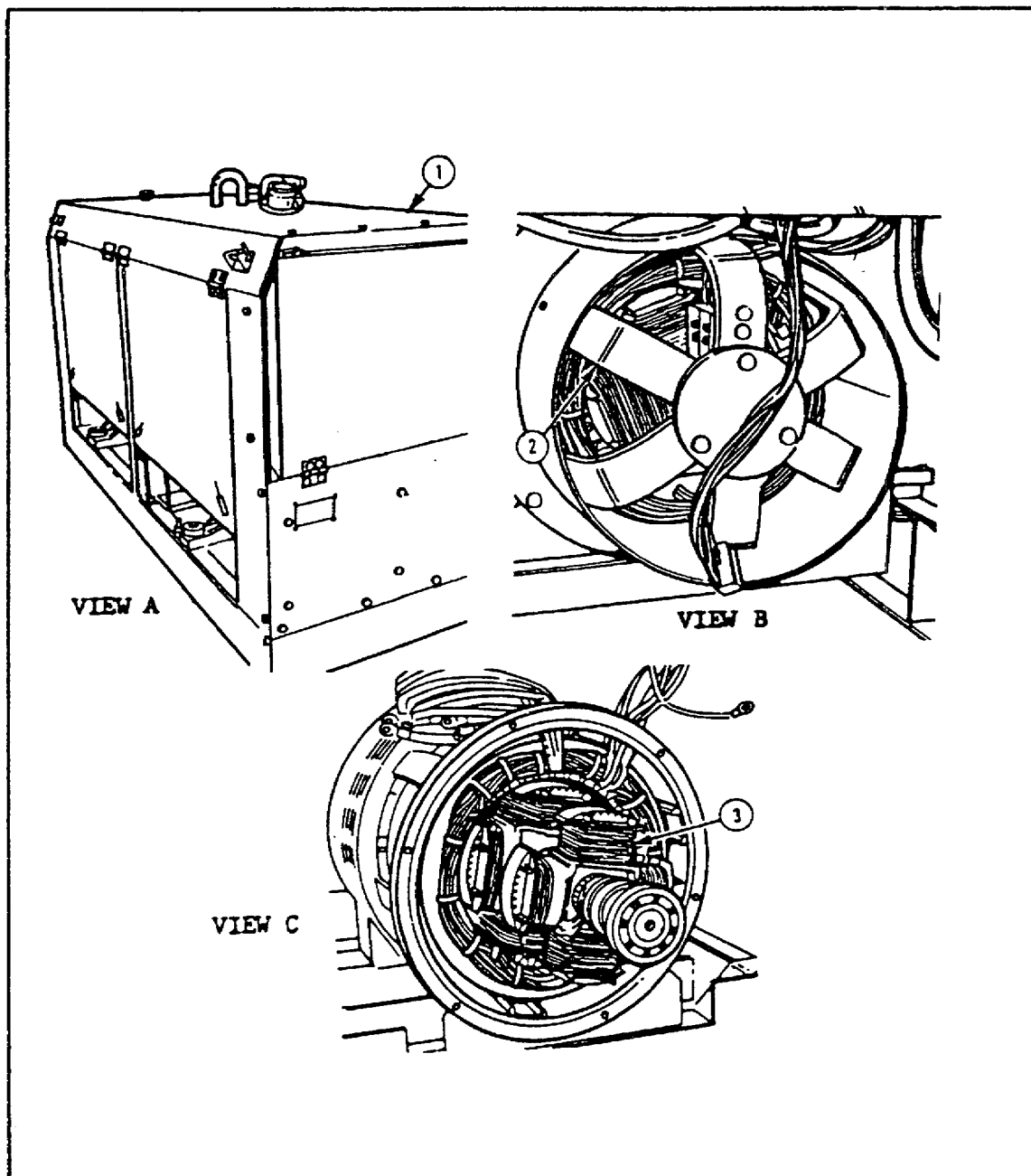

FIGURE 19. TOP COVER, EXCITER, AND ARMATURE ASSEMBLIES.

(a) It is assumed that the welding machine top cover (1), the exciter assembly (2), and the armature assembly (3), all shown in figure 19 on the previous page, have been removed to provide access to check and replace the field coil assembly and housing;

(b) Remove the two bolts (1)(figure 20, view A), the locknuts (2), flatwashers (3), and one

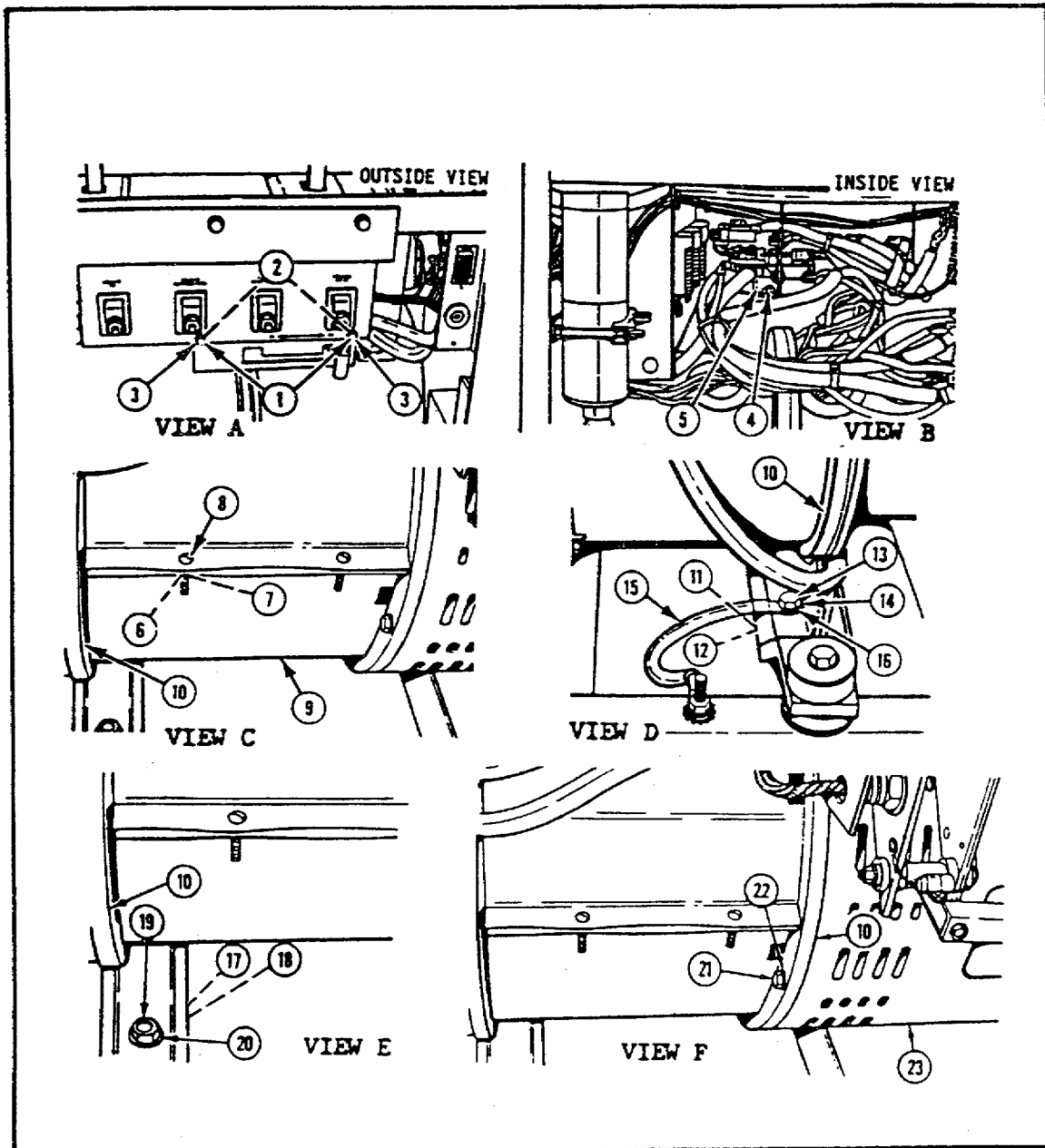

FIGURE 20. CHECKING THE FIELD COIL ASSEMBLY AND MODE SELECTOR SWITCH.

WELDING OPERATIONS II - OD1654 - LESSON 1/TASK 2

self-tapping bolt (4) (figure 20, view B, on the previous page), and lower the mode selector switch (5).

(c) Tag and remove the wire leads from the mode selector switch (5).

(d) Remove the two nuts (6) (figure 20, view C), two lockwashers (7), two screws (8), and cover (9) from the field coil assembly housing (10).

(e) Remove the mode selector switch (5) (figure 20, view B).

(f) Remove the nut (11) (figure 20, view D), lockwasher (12), bolt (13), flat washer (14), ground cable (15), and lockwasher (16) from the left side of the field coil assembly housing (10).

(g) Remove the nut (17) (figure 20, view E), lockwasher (18), bolt (19), and flat washer (20) from the right side of the field coil assembly housing (10).

(h) Support the rear of the engine with a hoist connected to the engine rear head lifting eye.

Step 7. Check for defective ballast assembly. If defective, replace as follows: (Refer to figure 21, view A, on the following page.)

(a) Tag and remove ballast electrical wire.

(b) Remove two nuts (1) and two lockwashers (2) from inside the welding machine frame.

(c) Support the ballast assembly (5) and remove the nut (6), lockwasher (7), bolt (8), and flat washer (9) from bracket (10).

(d) Remove the ballast assembly (5).

(e) Procure and install a new ballast assembly in the reverse order of removal.

Step 8. Check for defective contactor assembly. If defective, replace it as follows: (figure 21, view B).

(a) Tag and remove the electrical wire leads from the contactor assembly.

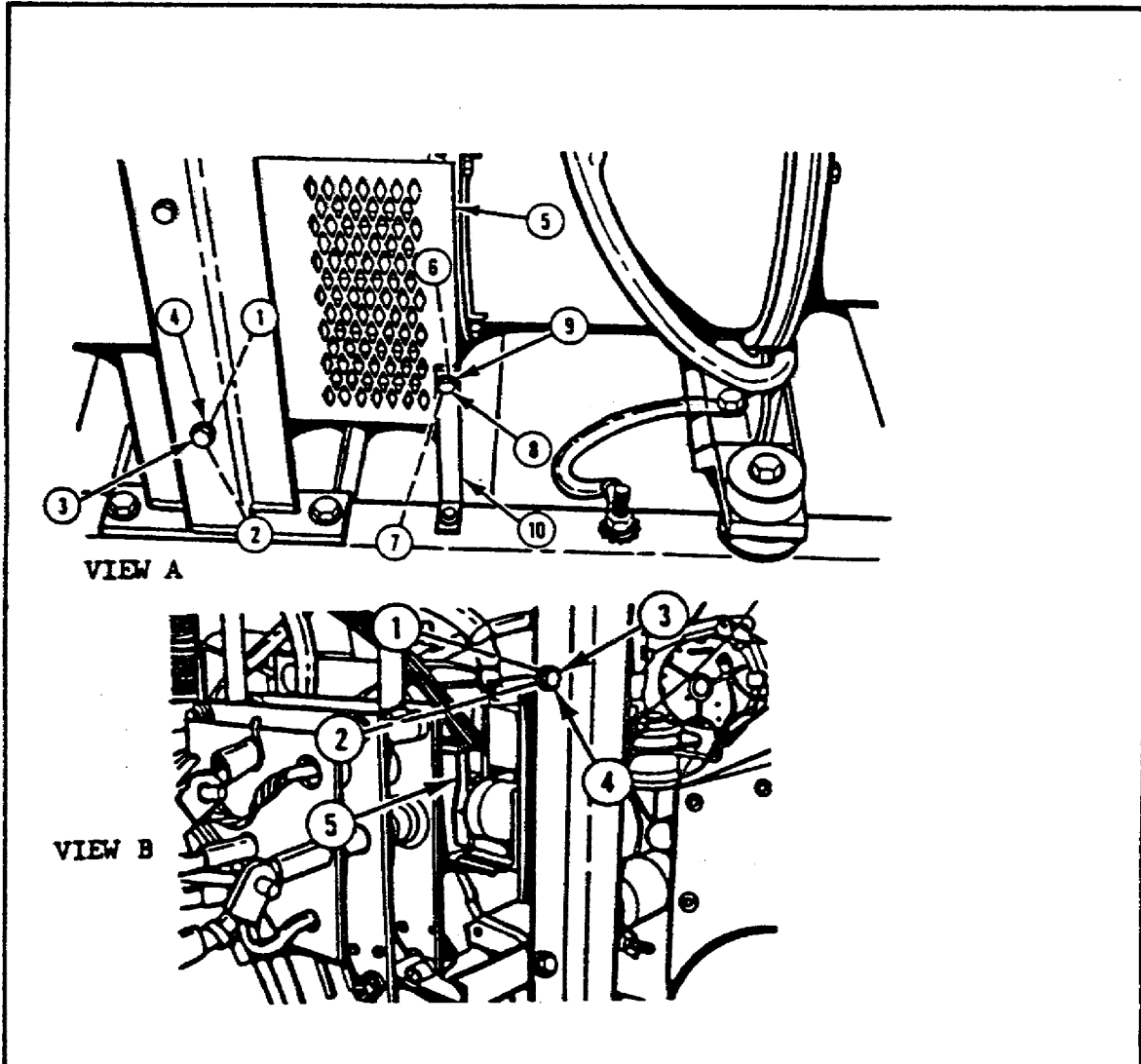

FIGURE 21. BALLAST AND CONTACTOR ASSEMBLIES.

(b) Remove four nuts (1), four lockwashers (2), four bolts (3), and four flat washers (4) from the welding machine frame.

(c) Remove the contactor assembly (5) from the welding machine frame.

(d) Procure and install a new contactor assembly in the reverse order of removal.

c. *Metal Inert Gas* (MIG) Welding Gun and Wire Feeder (figure 22 on the following page).

(1) *Welding Gun*. The welding gun is designed for use on all materials for which there is a compatible fillerwire. Such metals as steel, stainless steel, aluminum, magnesium, bronze, and

WELDING OPERATIONS II - OD1654 - LESSON 1/TASK 2

nickel alloys are easily welded with this gun. The gun is of a lightweight construction and uses a composite cable assembly which is comprised of control wires, gas hose, and power and feed cable in one assembly. The gun will handle 1/8 inch or smaller wire. Either solid or tubular wire may be used. It may use either carbon dioxide or argon/mixed gas for shielding of the welding process. When the gun actuator (1) is depressed, a timing circuit is activated in the wire feeder which starts the preflow of the shielding gas through the cable and welding gun to the work. The operator may vary the delay time by rotating the

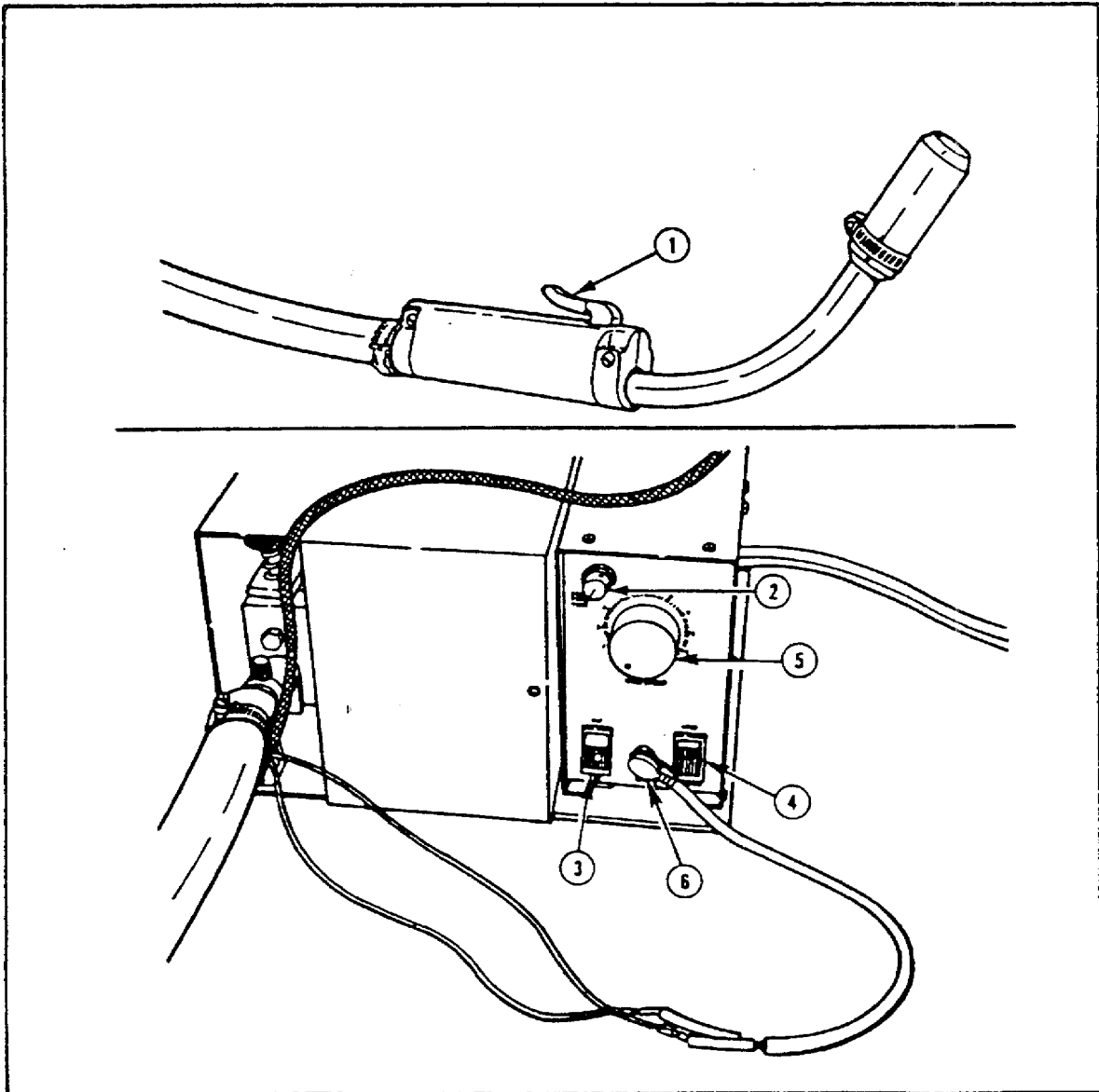

FIGURE 22. MIG WELDING GUN AND WIRE FEEDER.

potentiometer (2) (figure 22 on the previous page) on the wire feeder control box. Turning the rheostat clockwise increases the delay time, and turning it counterclockwise decreases the delay time. After the preflow delays, the welding current is delivered to the welding gun and automatic wire feeding begins.

(2) *Wire Feeder.* The wire feeder is comprised of a control box, interconnecting cables, enclosed feedheads, and wire mounting facilities to accommodate the different sizes of wire to be used in the various welding operations. The wire feeder ON/OFF power switch (3) is located on the front of the control box. It is activated by pressing on the top of the switch and deactivated by pressing on the bottom. An INCH-PURGE switch (4) is provided on the control box. By pressing on the top of the switch (INCH position), continuous wire feed is provided, and by pressing on the bottom of the switch (PURGE position), continuous gas flow is provided. This switch has a center OFF position. When the switch is released, it will return to the center OFF position. A wire speed control (5) is provided on the front of the control box to allow the operator to preset the wire feed speed. The wire may be fed from 30 to 500 inches per minute. Turning the speed control clockwise increases the wire feed speed and turning it counterclockwise decreases the wire feed speed. The divisions on the speed control dial are for reference only and do not reflect the rate of speed. A welding gun switch receptacle (6) is also provided on the front of the control box for plugging in the adapter.

(3) *Troubleshooting and Repair.*

(a) Listed below are the correct procedures that should be followed for troubleshooting and repair of the welding gun and wire feeder, specifically the malfunction: WIRE FEEDER MOTOR DOES NOT OPERATE ON INCH BUTTON OR GUN SWITCH, AND PILOT LIGHT IS LIGHTED.

Step 1. Check for a defective fuse in the back of the control box. If the fuse is defective, replace it as follows:

1 Push in on the fuseholder cap (1) (figure 23, on the following page). Turn the fuseholder cap 1/4 turn counterclockwise and remove the fuse cap holder.

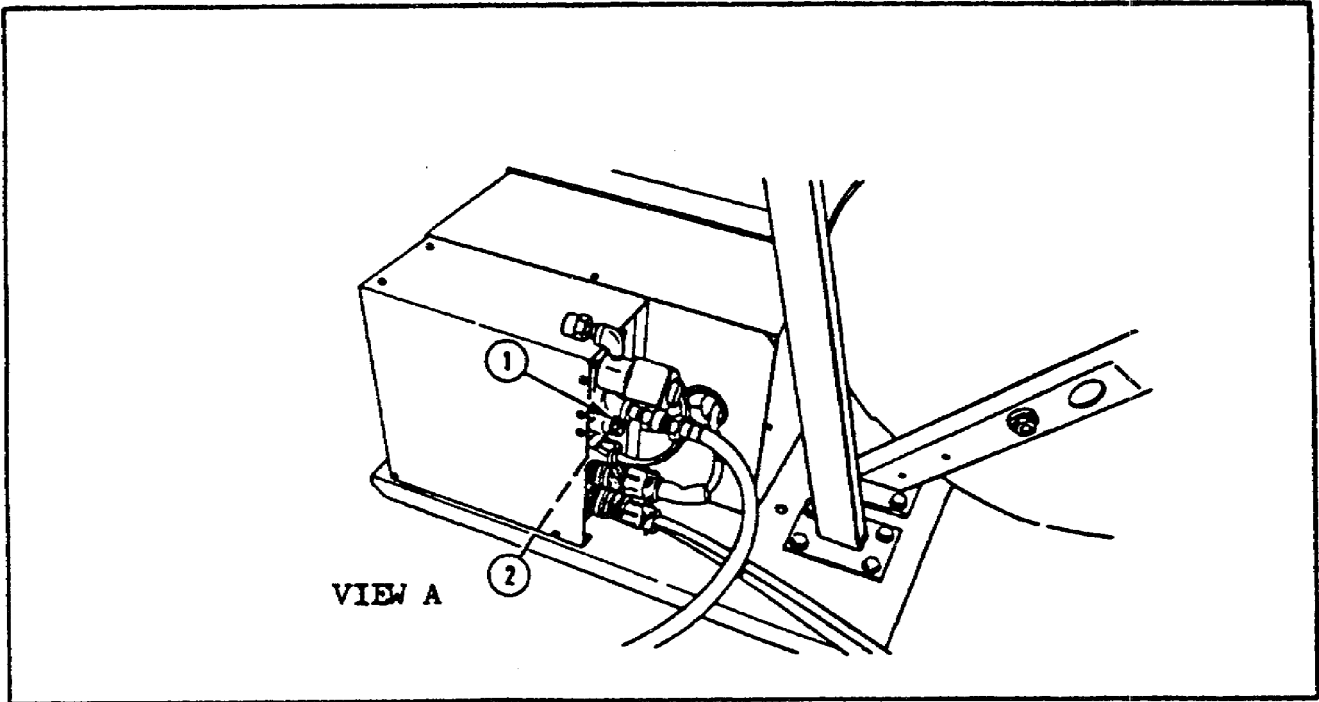

FIGURE 23. REPLACING THE FUSE.

2 Remove the defective fuse.

3 Procure a new fuse and install it in the reverse order of removal.

Step 2. Check the control cable and cable connection from the welding gun to the wire feeder. If either the cable or the cable connection are defective, order a replacement cable through supply channels. Do not attempt to repair this cable.

Step 3. Check the welding gun actuator. If defective, replace the welding gun actuator as follows:

DISASSEMBLY OF A WELDING GUN.

Step 1. Remove draw screws (1 and 2), shown in figure 24, view A, on the following page, from the front handle retainer (3) and rear handle retainer (4).

Step 2. Remove the front handle retainer (3), shown in figure 24, view B, and rear handle retainer (4) from the handle (5).

Step 3. Separate the halves of the handle (5), shown in figure 24, view C, to expose the welding gun tube (6) and the pushbutton switch (7).

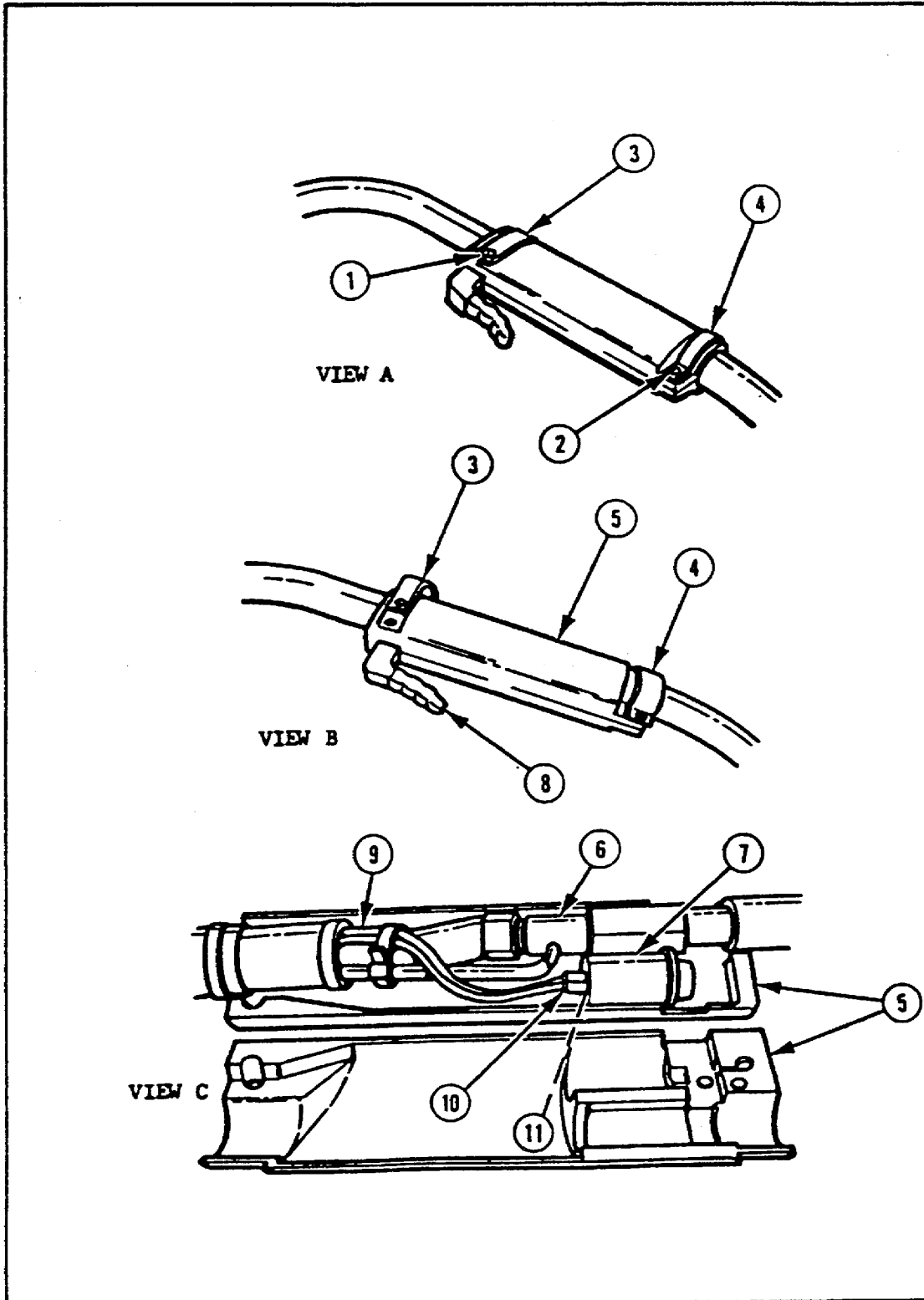

FIGURE 24. REPLACING WELDING GUN ACTUATOR.

WELDING OPERATIONS II - OD1654 - LESSON 1/TASK 2

Step 4. Remove the actuator (8) (figure 24, view B, on the previous page).

Step 5. Remove the cable assembly (9) (figure 24, view C), welding gun tube (6), and pushbutton switch (7).

Step 6. Unplug two terminals (10) from two pushbutton switch terminals (11) and remove the pushbutton switch (7).

CAUTION

Grasp the terminals (10) not the control wires, to remove the control wires from the pushbutton switch (7).

Step 7. Slide the cable assembly cover (12), shown in figure 25, view A, on the following page, back far enough to expose the end of the gas hose (13).

Step 8. Remove the gas hose (13) (figure 25, view A) from the copper tubing (14). The easiest way to remove the gas hose from the copper tubing is to cut it off at the end of the copper tubing.

Step 9. Unscrew the welding gun tube (6), as shown in figure 25, view B, from the cable assembly fitting (15) using two wrenches. Be careful when using two wrenches to unscrew the two fittings. It is possible to break off the gas tube from the welding gun.

PROCURE NEW ACTUATOR AND REASSEMBLE WELDING GUN AS FOLLOWS:

Step 1. Using two wrenches, screw the threaded end of the welding gun tube (6), shown in figure 25, view B, into the cable assembly fitting (15).

Step 2. Moisten the copper tubing (14), shown in figure 25, view C, and slide the gas hose (13) over the copper tubing approximately 1/2 inch. Approximately one inch of copper tubing should be exposed beyond the end of the gas hose tubing.

Step 3. Plug the two terminals (10), shown in figure 26, view A, on page 60, into two pushbutton switch terminals (11)

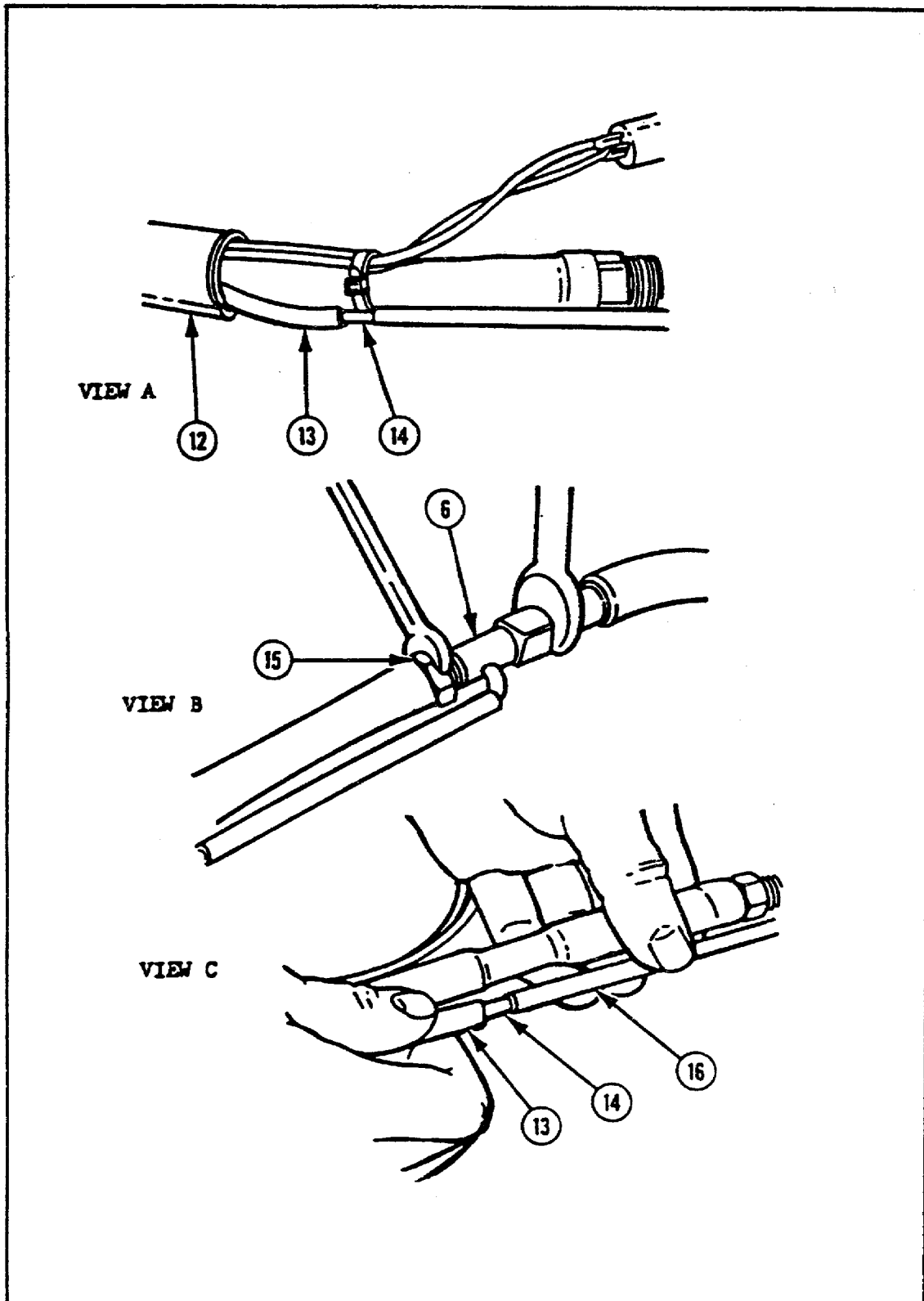

FIGURE 25. REPLACING WELDING GUN ACTUATOR (CONTINUED).

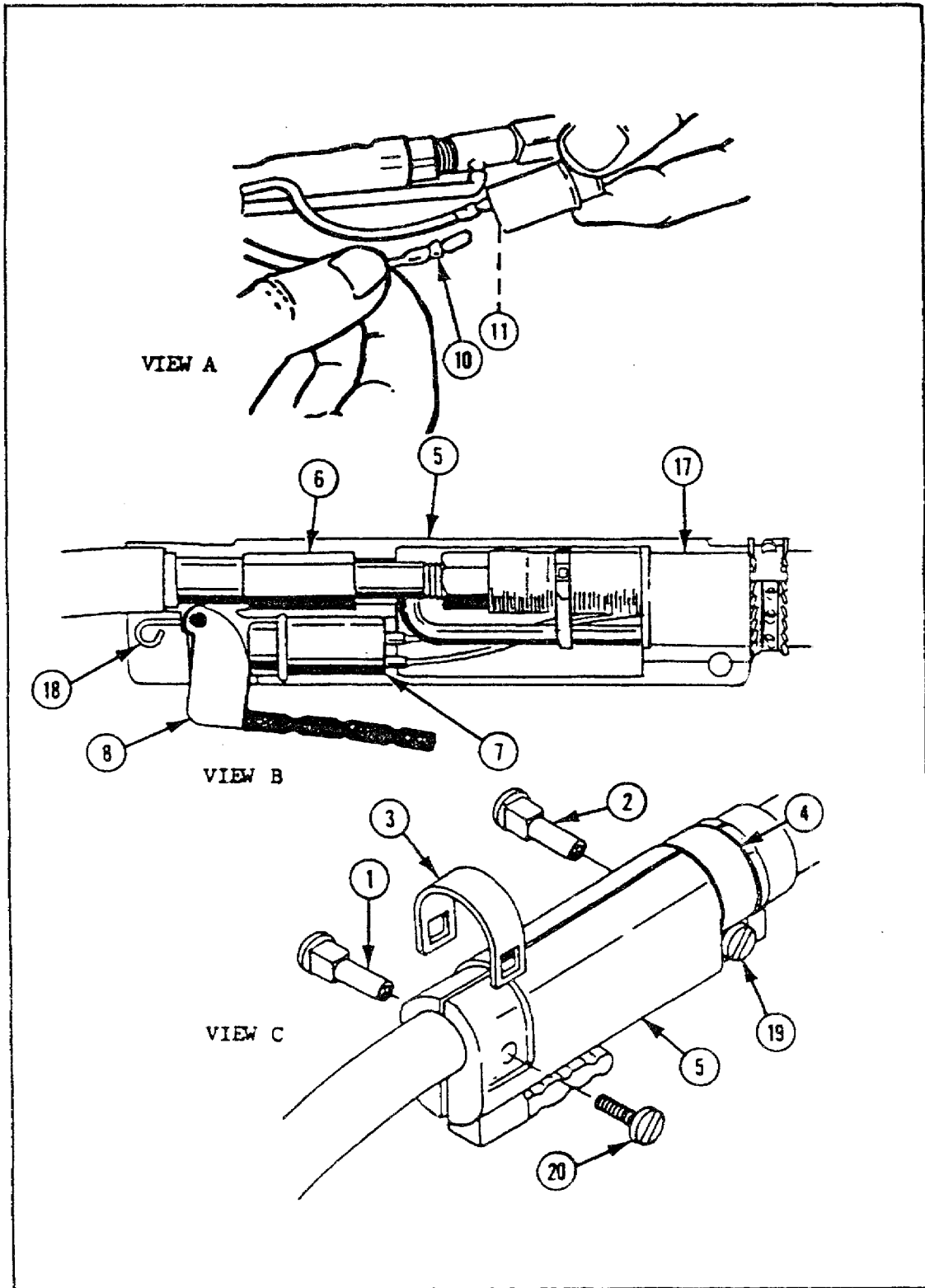

FIGURE 26. REPLACING WELDING GUN ACTUATOR (CONTINUED).

WELDING OPERATIONS II - OD1654 - LESSON 1/TASK 2

Step 4. Slide the cable assembly cover (17), shown in figure 26, view B, on the previous page, over the cable assembly so that it extends inside the handle (5).

Step 5. Install the welding gun tube (6) with cable assembly attached into the right half of the handle (5). Place the pushbutton switch (7) in the cavity provided.

Step 6. Position the spring (18) and actuator (8) in the right half of the handle (5) with the front of the spring in the groove provided.

Step 7. Place the left half of the handle (5), shown in figure 26, view C, in position; and install rear handle retainer (4) and front handle retainer (3).

Step 8. Insert draw screw (2) through the rear of the handle retainer (4). Install and tighten the screw (19).

Step 9. Insert the draw screw (1) through the front handle retainer (3). Install and tighten the screw (20).

If the welding gun activator is not defective, open the control box and observe the control relay while squeezing the welding gun actuator to see if it is working. If it is not working properly, clean the relay contacts with a fine file or Number 00 sandpaper. If cleaning does not solve the problem, replace the control relay as follows:

Step 1. Remove four screws, washers, and lockwashers (1) (figure 27, view A, on the following page) from the bottom of the wire feeder baseplate (2) that secures the control box (2a) to the wire feeder baseplate.

Step 2. Disconnect the wire feeder control cable (3), shown in figure 27, view B, the motor control cable (4), and the gas control valve plug (5) from the back of the control box and remove the control box.

Step 3. Remove two screws, washers, and lockwashers (6) from the top front of the control box that secures the control box front panel.

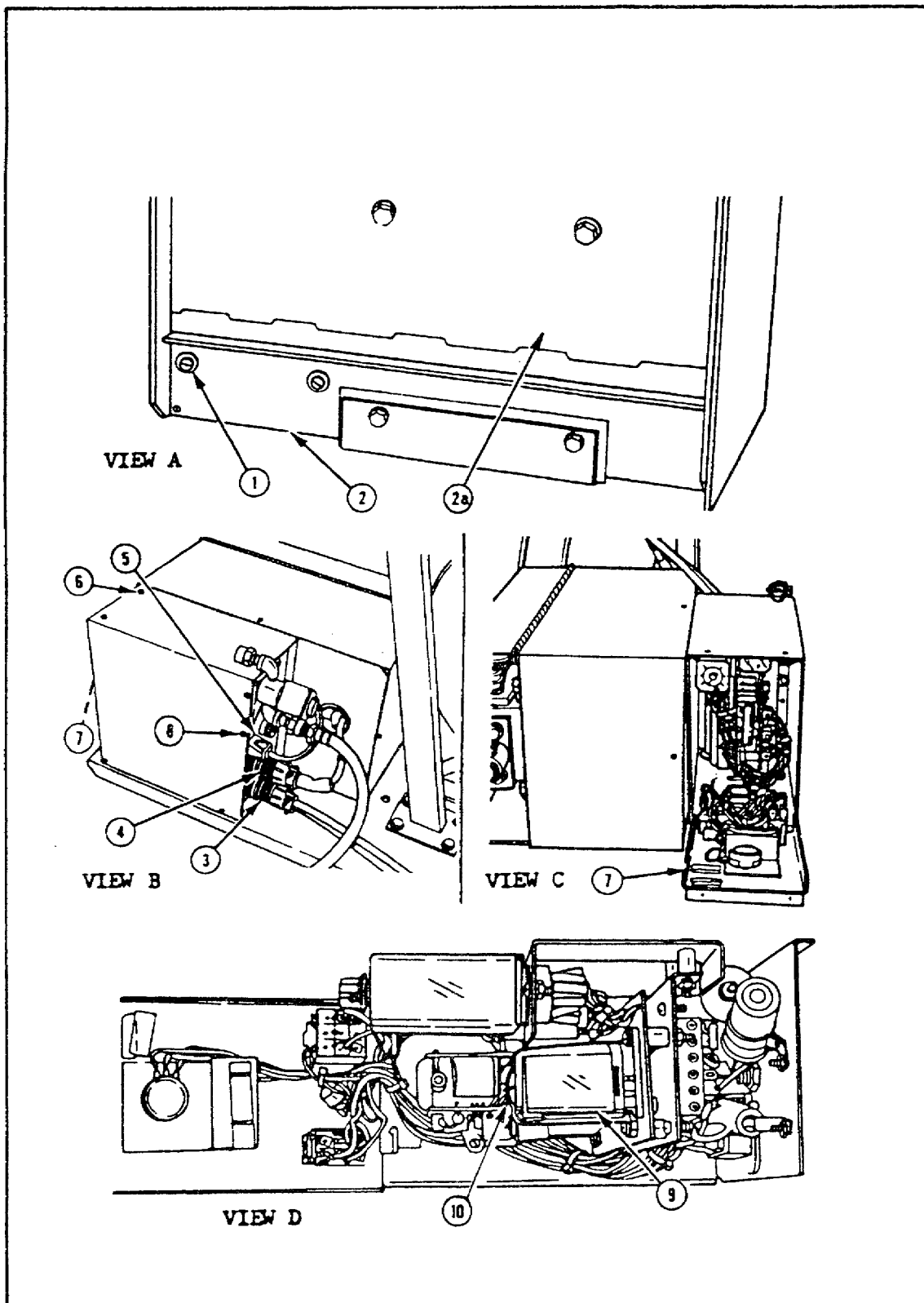

FIGURE 27. REPLACING THE CONTROL RELAY.

WELDING OPERATIONS II - OD1654 - LESSON 1/TASK 2

Step 4. Lower the control box front panel (7) (figure 27, views B and C).

Step 5. Remove six screws (8) (figure 27, view B, on the previous page) that secure the cover of the the control box and slide off the cover.

Step 6. Remove the control (keying) relay (9) (figure 27, view D) (24 volts alternating current relay) by holding the retaining wire (10) up and pulling the control relay out of the socket.

Step 7. Procure a new control (keying) relay and install in the reverse order of removal.

If the control relay is not defective, check the brushes on the feed motor. If the brushes are less than 3/8 inch long, replace them as follows:

Step 1. Disconnect the cable connector (1), (figure 28, view A, on the following page) from the feed motor (2).

Step 2. Remove the wire guide (2a) from the bracket (2b).

Step 3. Remove the four bolts, washers, and lockwashers (3) that secures the gear reduction unit (4) to the wire feeder baseplate (5).

Step 4. Slide the gear reduction unit (4) and the feed motor (2) out of the cover.

Step 5. Unscrew the two bakelite caps (6) (figure 28, view B) on the sides of the feed motor (2).

Step 6. Remove the two motor brushes (7) from the feed motor (2).

Step 7. Procure two new brushes and install in the reverse order of removal.

If new brushes do not solve the problem, replace the feed motor as follows:

Step 1. Disconnect the cable connector (1) (figure 29, view A, on page 65).

Step 2. Remove the four bolts, washers, and lockwashers (2) from the bottom of the wire feeder baseplate (3).

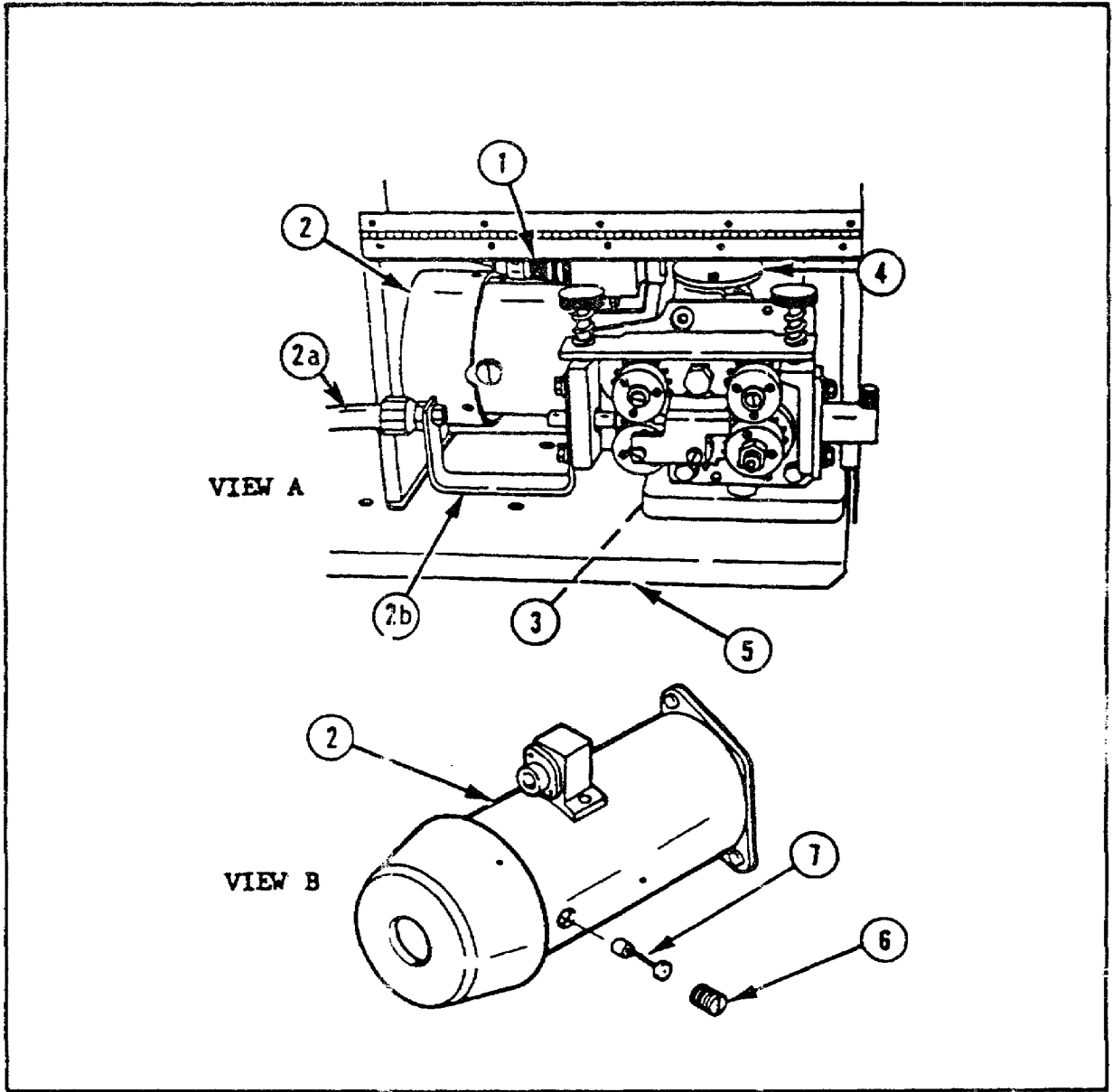

FIGURE 28. REPLACING THE FEED MOTOR BRUSHES.

Step 3. Remove the wire guide (4) from the bracket (5).

Step 4. Slide the feed motor (6) (figure 29, view A, on the following page) and gear reduction unit (7) out of the cover (3a).

Step 5. Remove the two bolts and lockwashers (8) (figure 29, view B), attaching the feed motor (6) to the gear reduction unit (7), and remove the feed motor (6).

Step 6. Procure a new motor and install in the reverse order of removal.

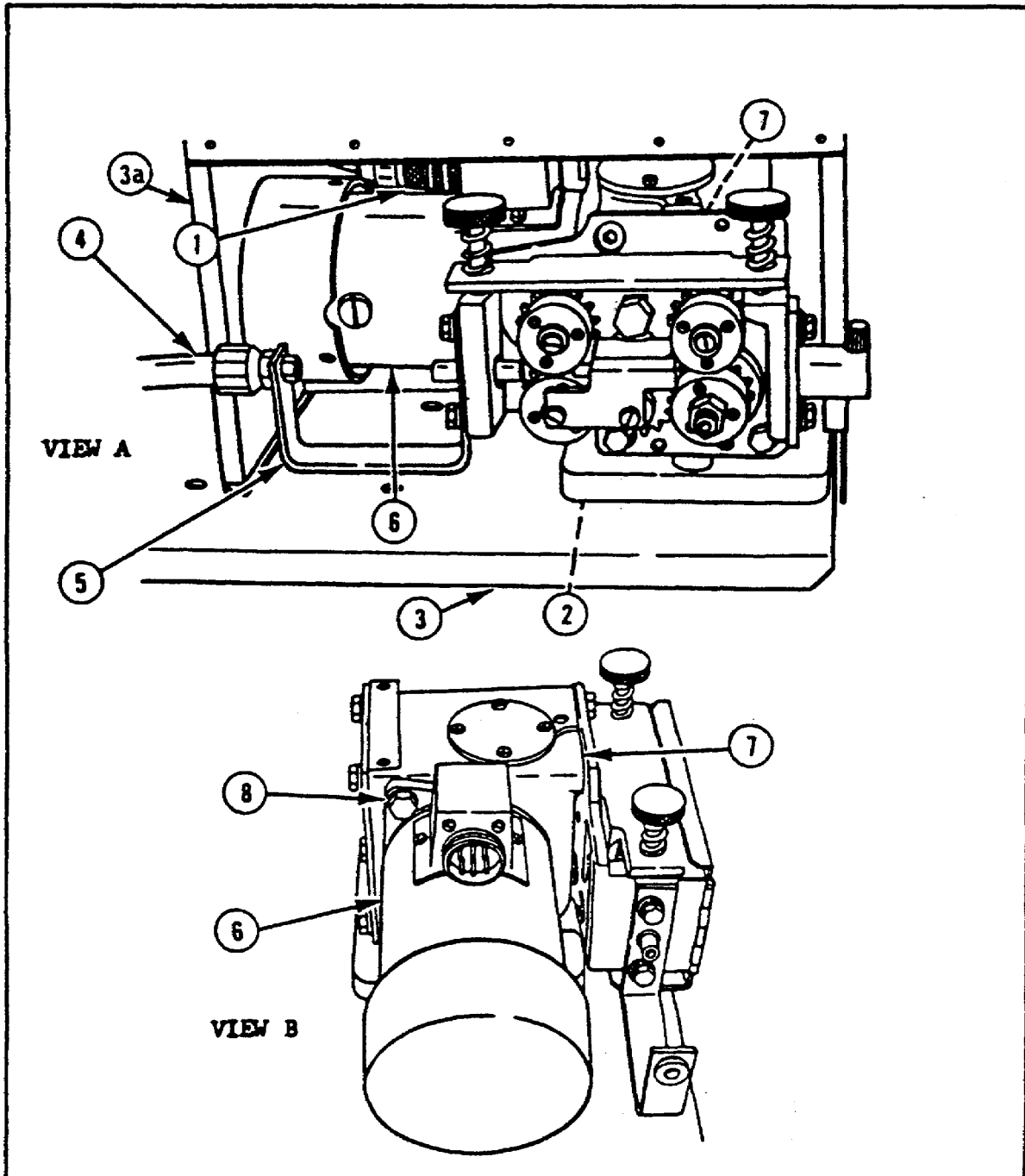

FIGURE 29. INSTALLING FEED MOTOR.

(b) Listed below are correct procedures to follow for troubleshooting and repair of the wire feeder and welding gun, specifically the malfunction: WIRE FEEDER FEED MOTOR OPERATES, BUT THE WIRE DOES NOT FEED.

Step 1. Check the pressure adjustments on the wire feed roll pressure plate. If there is not enough pressure, increase the pressure as follows:

WELDING OPERATIONS II - OD1654 - LESSON 1/TASK 2

WARNING

The drive mechanism of the wire feeder and spool is at welding potential any time the welding machine is turned on and the welding gun actuator is depressed. Death may result if contact is made with the welding wire or rollers.

1 Ensure that the wire electrode (3a) (figure 30, view A, on the following page) has been threaded through the wire spool guide (3) and through the feed rollers (5).

2 Tighten two pressure plate adjusting screws (6) (one adjusting screw not shown in figure 30) until resistance is felt.

Step 2. Check the size stamped on the wire roll. If the installed wire is not the correct size, install the proper size wire on the wire feeder as follows:

WARNING

If the welding cable is connected to the composite cable adapter, disconnect it before installing in the wire feeder. If any wire remains in the welding gun and composite cable, pull it out from the welding gun end before attempting to install new wire.

1 Ensure that the control cable (1) (figure 30, view B) from the wire feeder control box is connected to the welding machine CONTROL receptacle.

2 Connect the wire feeder power cable (2) to a 115 volts alternating current receptacle on the welding machine.

3 Remove the spool cover (1), shown in figure 30, view C.

4 Unscrew and remove the wire spool hub nut (2) (figure 30, view A) and remove the incorrect size wire spool.

5 Install a spool of the correct size wire. (A list of the proper size wires for use with this

welding machine are listed in TM 9-3431-265-14&P.) Install the wire spool on the hub so that the wire will unwind in a counterclockwise rotation. Tighten the wire spool hub nut (2) (figure 30, view A).

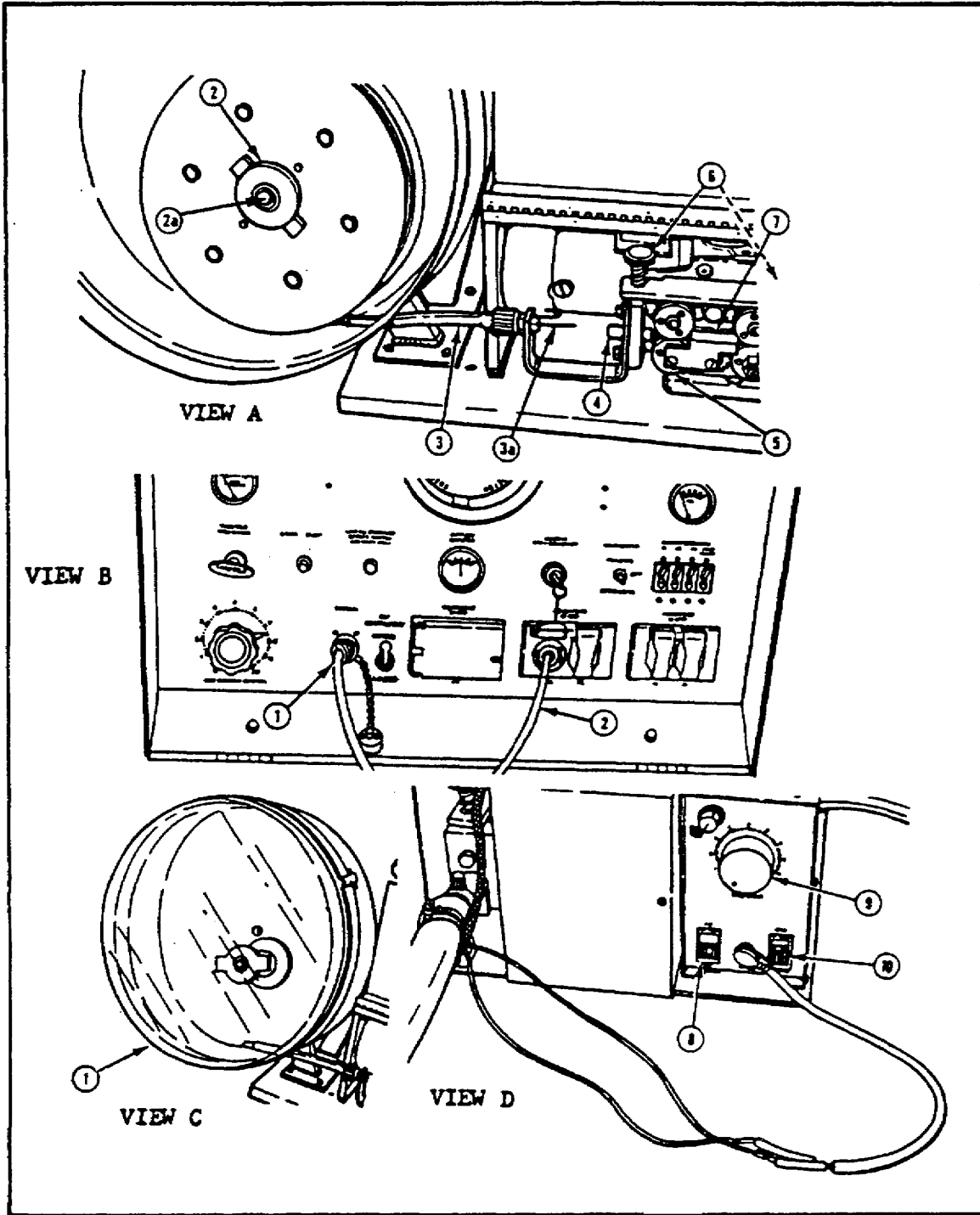

FIGURE 30. INSTALLING THE WIRE SPOOL.

WELDING OPERATIONS II - OD 1654 - LESSON 1/TASK 2

6 Cut the wire loose from the side of the spool and unwind about one foot of wire. Thread the wire through the wire spool guide (3) (figure 30, view A, on the previous page) and the input guide (4) until it is up against the feed rollers (5). Use a pencil or other soft material to help guide the wire through the feed rollers. Your fingers could catch in the rollers if you try guiding the wire with your hands.

7 Loosen the pressure plate adjusting screws (6) feed the wire through the feed rollers and into the center guide (7); then tighten the pressure plate adjusting screws (6) until resistance is felt.

8 Turn the wire feeder power switch (8) (figure 30, view D) to the ON position, and turn the wire speed control (9) to the mid-point position.

9 Start the welding machine.

10 Depress the top (INCH) of the INCH-PURGE switch (10), to slowly feed the wire through the roller and into the composite cable. Observe the wire roll while the wire is being fed into the composite cable to make sure that it does not stop feeding off the roll. Damage to equipment may result if the wire binds and stops feeding through the cable. If the wire stops feeding, release the INCH-PURGE switch until the source of the binding is located and eliminated.

WARNING

Turn off the welding machine before connecting the positive welding cable to the composite cable adapter flange.

11 Allow the wire to feed through the cable and welding gun until it sticks out of the end of the welding gun; then turn the INCH-PURGE switch to the OFF position.

12 Cut off any excess wire sticking out of the welding gun.

13 Install the spool cover (1) (figure 30, view C).

WELDING OPERATIONS II - OD1654 - LESSON 1/TASK 2

Step 3. Check the wire spool brake pressure. If there is too much brake pressure, decrease the pressure by turning the hub screw (2a), shown in figure 30, view A, on page 67, in a counterclockwise direction.

Step 4. Examine the cable, welding gun, and current contact tip for damage and correct size contact tip and cable liner. Replace damaged or unserviceable parts by following the troubleshooting and repair procedure described in step 3 of paragraph 3c(3) (a) on page 56.

(c) Listed below are the correct procedures to follow for troubleshooting and repair of the wire feeder and welding gun, specifically the malfunction: WIRE FEEDS, BUT NO GAS FLOWS.

Step 1. Ensure that the gas cylinder valve (17) (figure 31, view A on the following page) is open. Turn the flowmeter adjustment valve (18) to adjust the rate of the shielding gas flow.

Step 2. Check for gas in the cylinder by observing the regulator meter (17a), for gas pressure while opening the gas valve (17). If the regulator does not indicate any gas pressure, replace the gas cylinder as follows:

1 Close the gas cylinder valve (17).

2 Disconnect the gas supply hose (19) from the flowmeter (20).

3 Procure a full gas cylinder and install it in the reverse order of removal.

Step 3. Check for restrictions in the gas line. If the flexible gas line is twisted it can be straightened out by untwisting it. A kinked or bent rigid line must be replaced with a new one. The procedure for replacing a bent or kinked rigid line involves unscrewing the gas line fittings connecting it to the gas cylinder, the control box, and the welding gun, then screwing on the fittings of the new line to the aforementioned components.

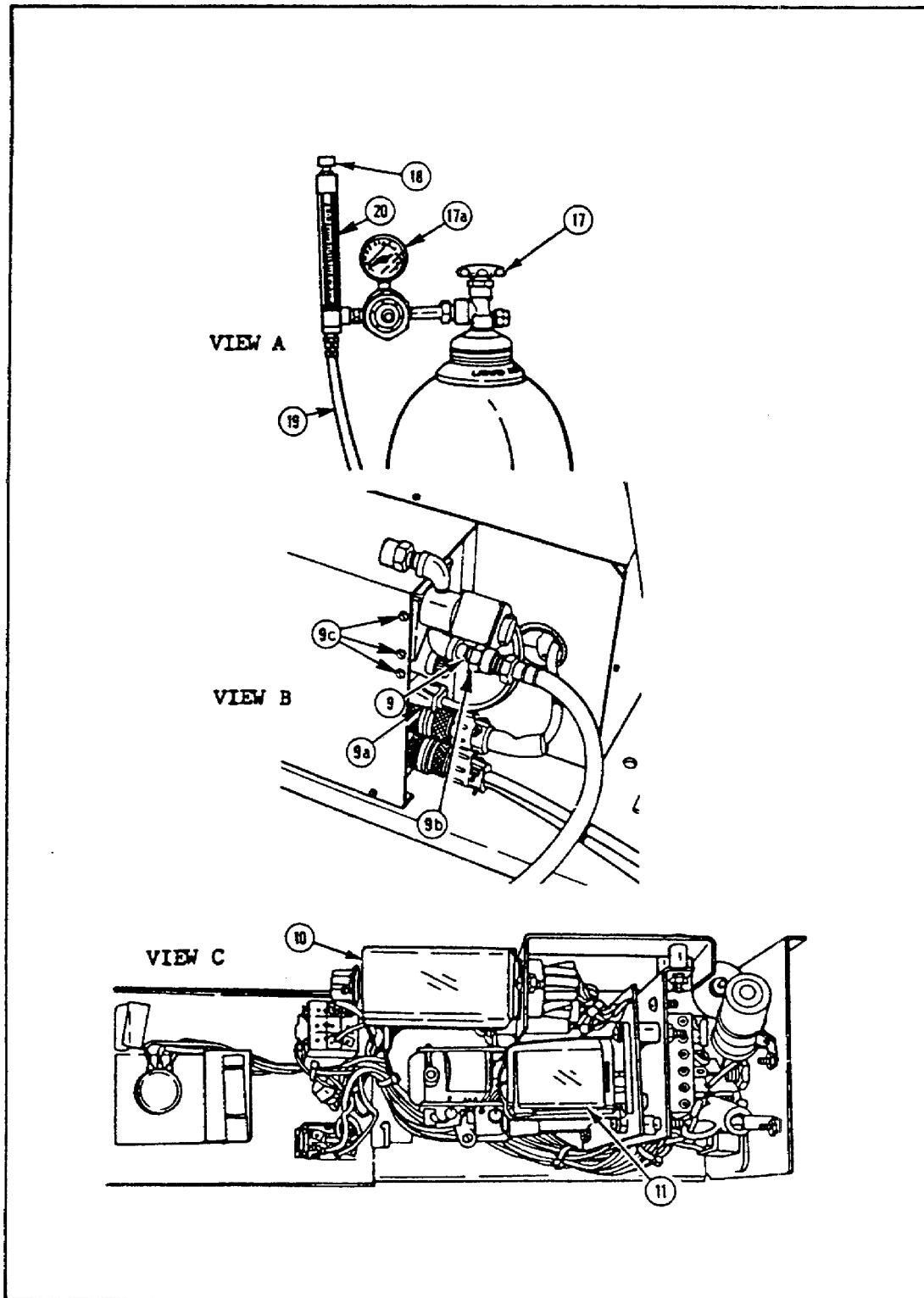

FIGURE 31. CHECKING FOR GAS, DEFECTIVE GAS VALVE, SOLENOID, AND TIME DELAY RELAY.

WELDING OPERATIONS II - OD1654 - LESSON 1/TASK 2

Step 4. Check for loose or broken electrical wires to the gas valve solenoid (9) (figure 31, view B, on the previous page) and to the time delay relay (10) (figure 31, view C). Clean and tighten all loose electrical wires and repair or replace all broken electrical wires. Refer to FM 55-605-1 for the repair of electrical wires and cables to electrical/electronic equipment.

Step 5. Listen for the gas solenoid to activate after time delay. If the gas solenoid or the time delay relay is defective, replace as follows:

1 To replace the gas solenoid unplug the electrical connection (9a) (figure 31, view B) and disconnect the flowmeter line fitting (9b) to the gas solenoid.

2 Remove three screws (9c) which hold the gas solenoid to the control box.

3 Remove the defective gas solenoid (9.) from the control box.

4 Procure a new gas solenoid and install it in the reverse order of removal.

5 Replace the time delay relay (10) (figure 31, view C).

CAUTION

In this case, be careful not to replace the control (keying) relay (11).

4. Conclusion

This second task described the procedures for troubleshooting welding equipment and determining the methods of repair. A practical exercise which the student is required to complete by providing answers to the questions follows.

WELDING OPERATIONS II - OD1654 - LESSON 1/PE 1

PRACTICAL EXERCISE 1

1. Instructions

On a plain piece of paper, respond to the requirement listed below.

2. Requirement

Successful completion of this exercise provides indication of success in the subcourse. Check your answers against those provided on the answer page following the questions.

- a. Name one of the two inert gas welding methods mentioned in this lesson.
- b. Name two of the four potential hazards of inert gas shielding arc welding.
- c. What gas hazard is presented by gas tungsten-arc cutting of stainless steel, using a 90 percent nitrogen 10 percent argon mixture?
- d. What types of radiation are produced by the arc welding arc as well as by the oxyacetylene gas flames?
- e. Name two of the four shielding gases used for inert gas welding.
- f. Which of the two inert gas welding processes mentioned in this lesson is used to weld thicker metal?
- g. What inert gas welding process uses a consumable bare metal electrode?
- h. What type electrical current is used to perform inert gas welding?
- i. What type inert gas permits better control of the molten metal pool and of the arc during welding?
- j. Tungsten electrode are identified as to type by different color marks painted on one end of the electrode. What type tungsten electrode is identified by a red mark?

WELDING OPERATIONS II - OD1654 - LESSON 1/PE 1

- k. What is the advantage of dressing down one end of the tungsten electrode to a point?
- l. What metals can be welded with the MIG and TIG welding processes?

WELDING OPERATIONS II - OD1654 - LESSON 1/PE 1

LESSON 1. PRACTICAL EXERCISE - ANSWERS

1. Requirement
 - a. (1) tungsten inert gas (TIG)
(2) metal inert gas (MIG)
 - b. (1) gases
(2) radiant energy
(3) radioactivity from thoriated tungsten electrodes
(4) metal fumes
 - c. Nitrogen oxide
 - d. Ultraviolet and infrared rays
 - e. (1) argon
(2) helium
(3) argon-helium mixtures
(4) carbon dioxide
 - f. Metal inert gas (MIG)
 - g. MIG
 - h. Alternating current or direct current.
 - i. Argon
 - j. Two percent thorium
 - k. Better control of the arc
 - l. Ferrous and nonferrous

REFERENCES

WELDING OPERATIONS II - OD1654 - REFERENCES

REFERENCES

The following documents were used as resource materials in developing this subcourse:

TM 9-237

TM 9-3431-265-14&P

TM 9-3431-266-14&P